

PAPEL DE ACUARELA CON FORMATO A4

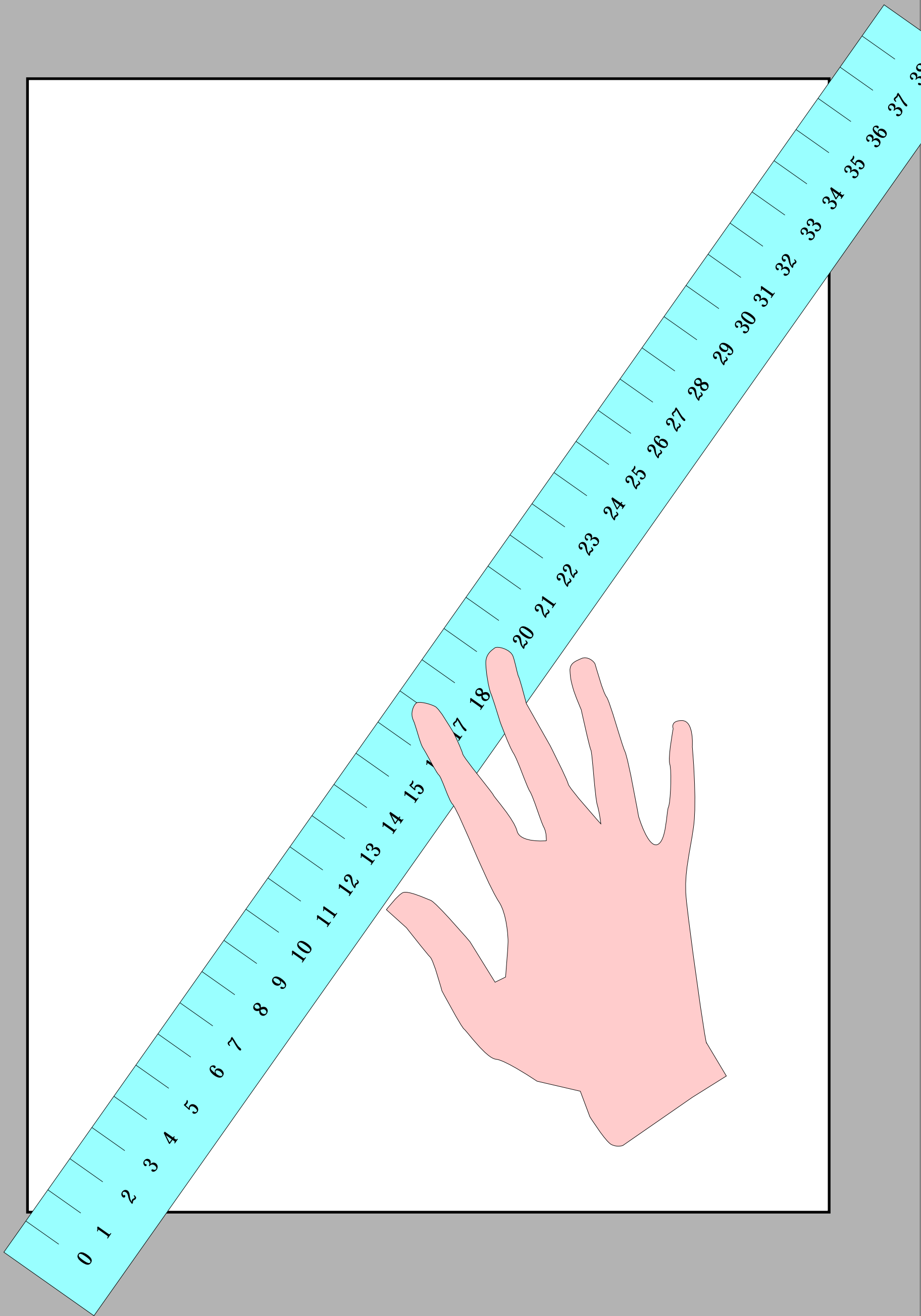

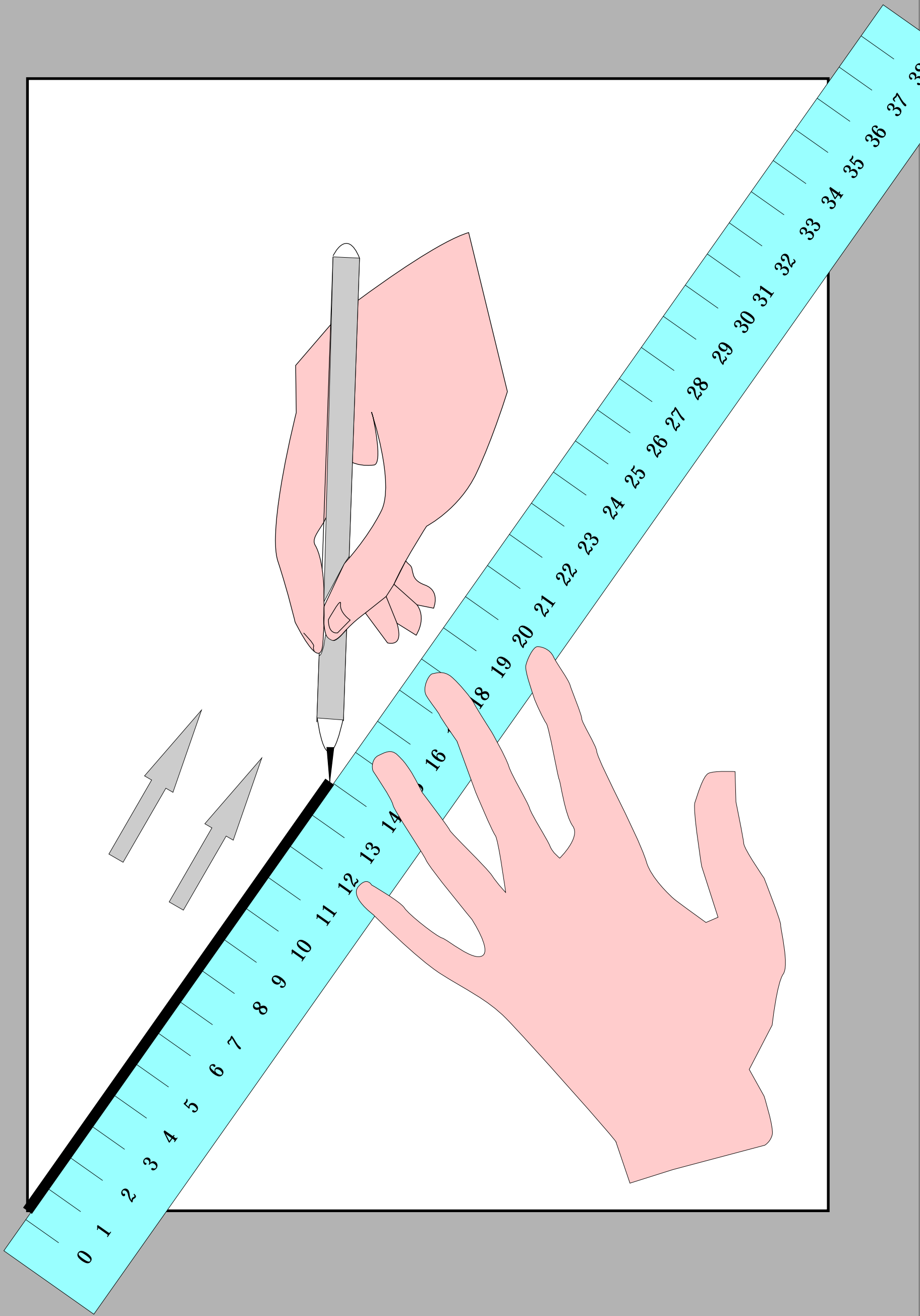

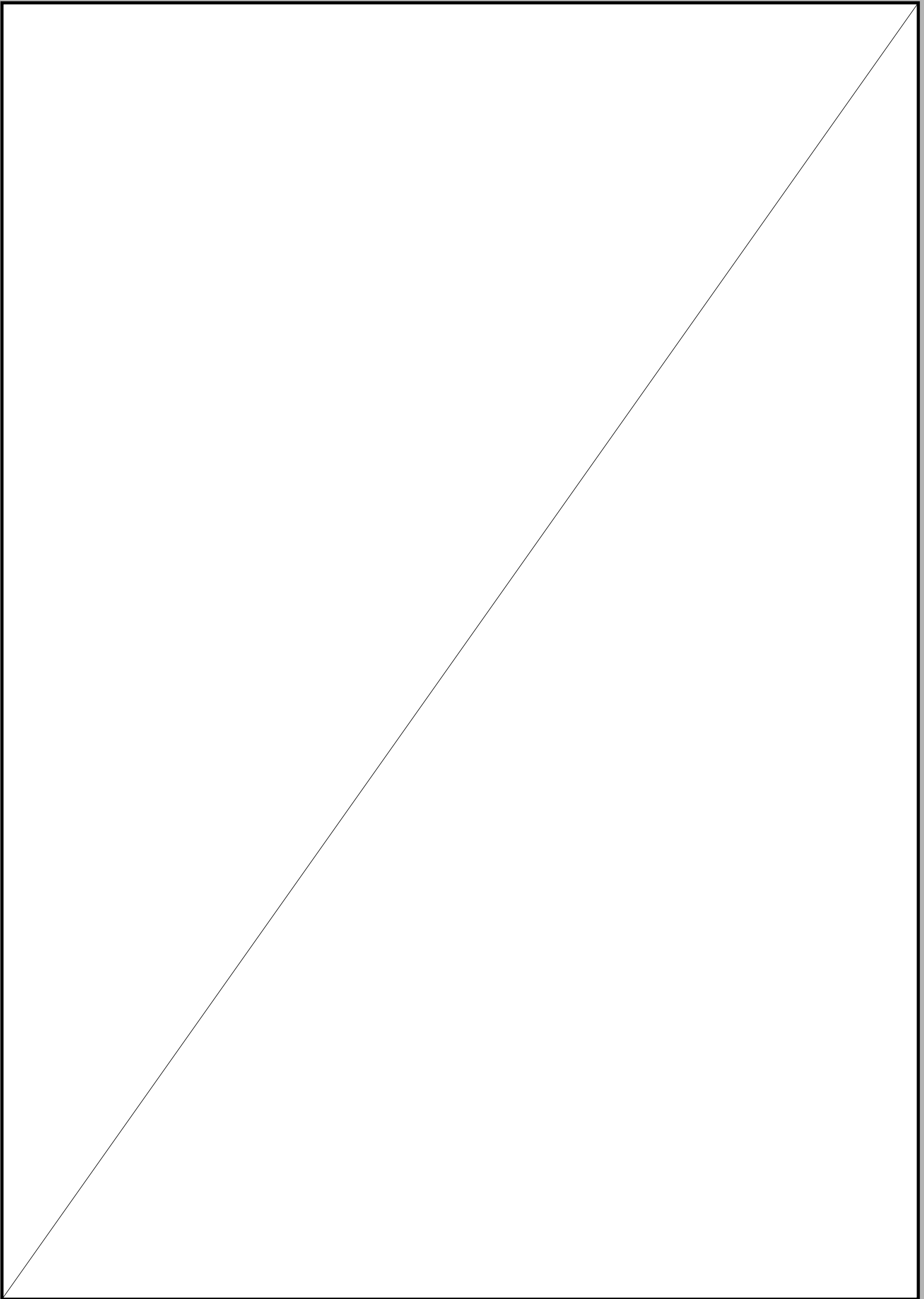

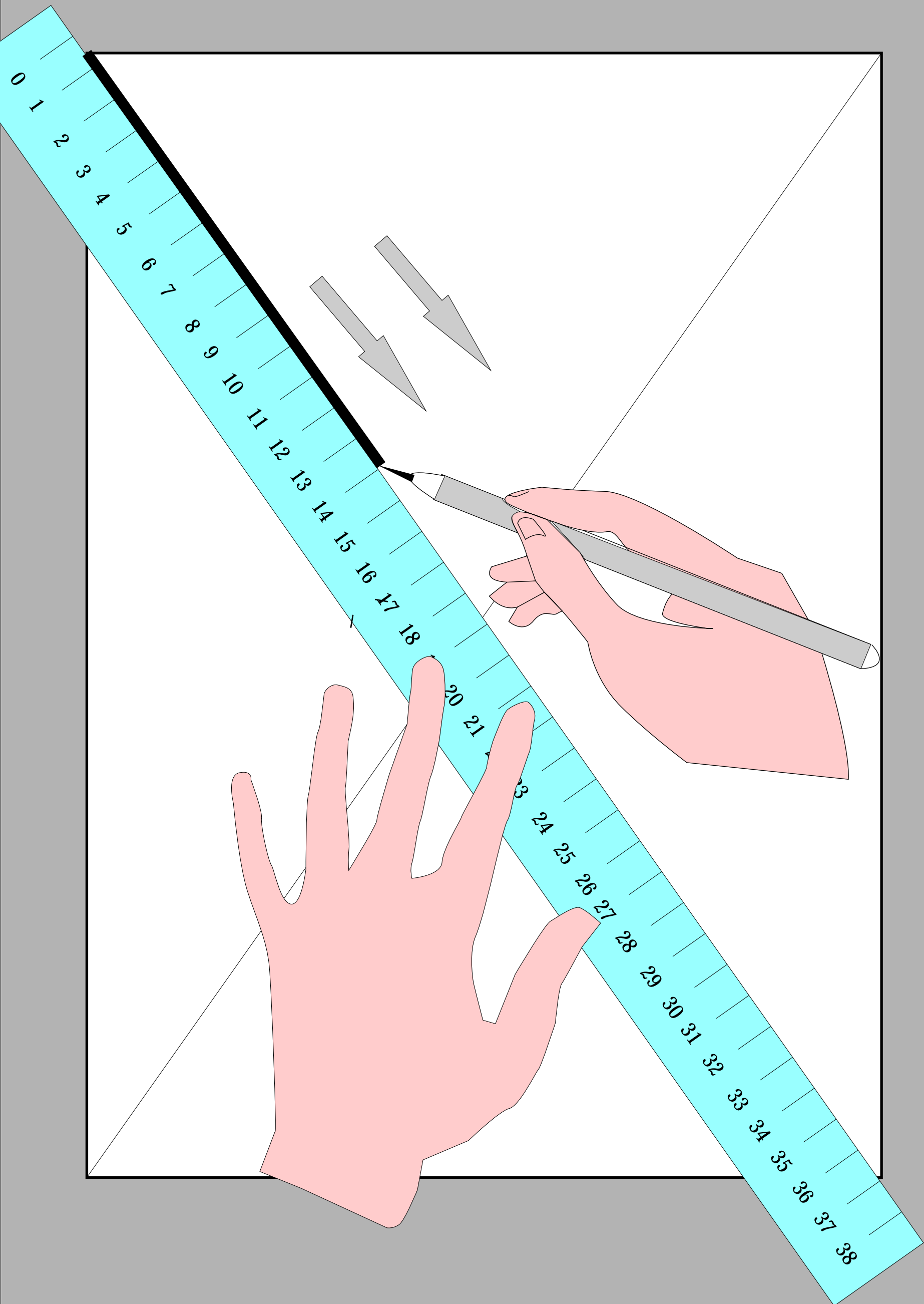

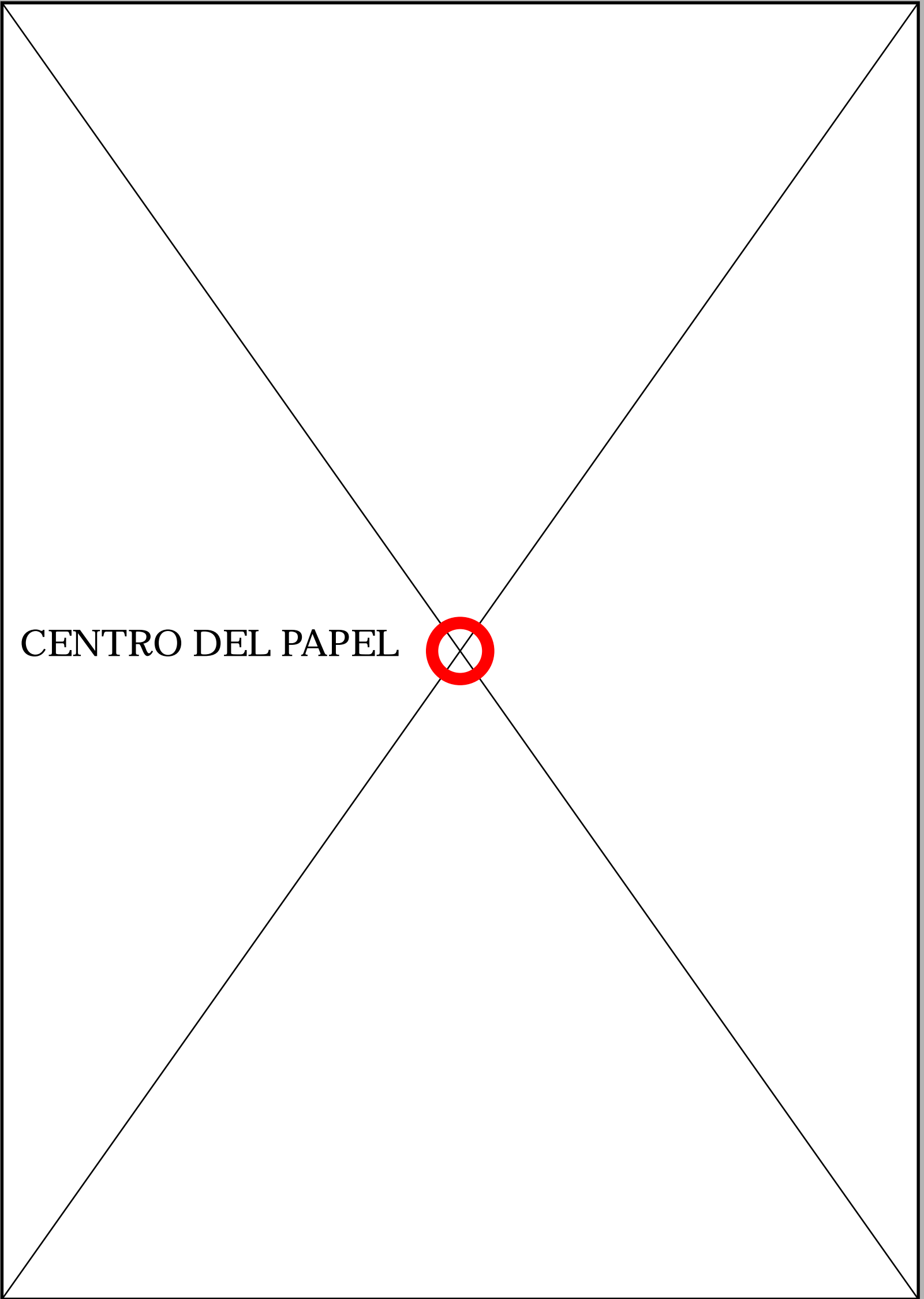

CENTRO DEL PAPEL

**BORRAR LAS DIAGONALES. SÓLO SE DEJA
VISIBLE EL PUNTO CENTRAL (DONDE SE
CORTAN).**

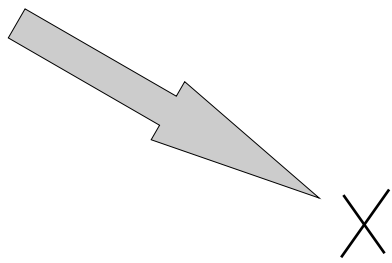

ALINEAR

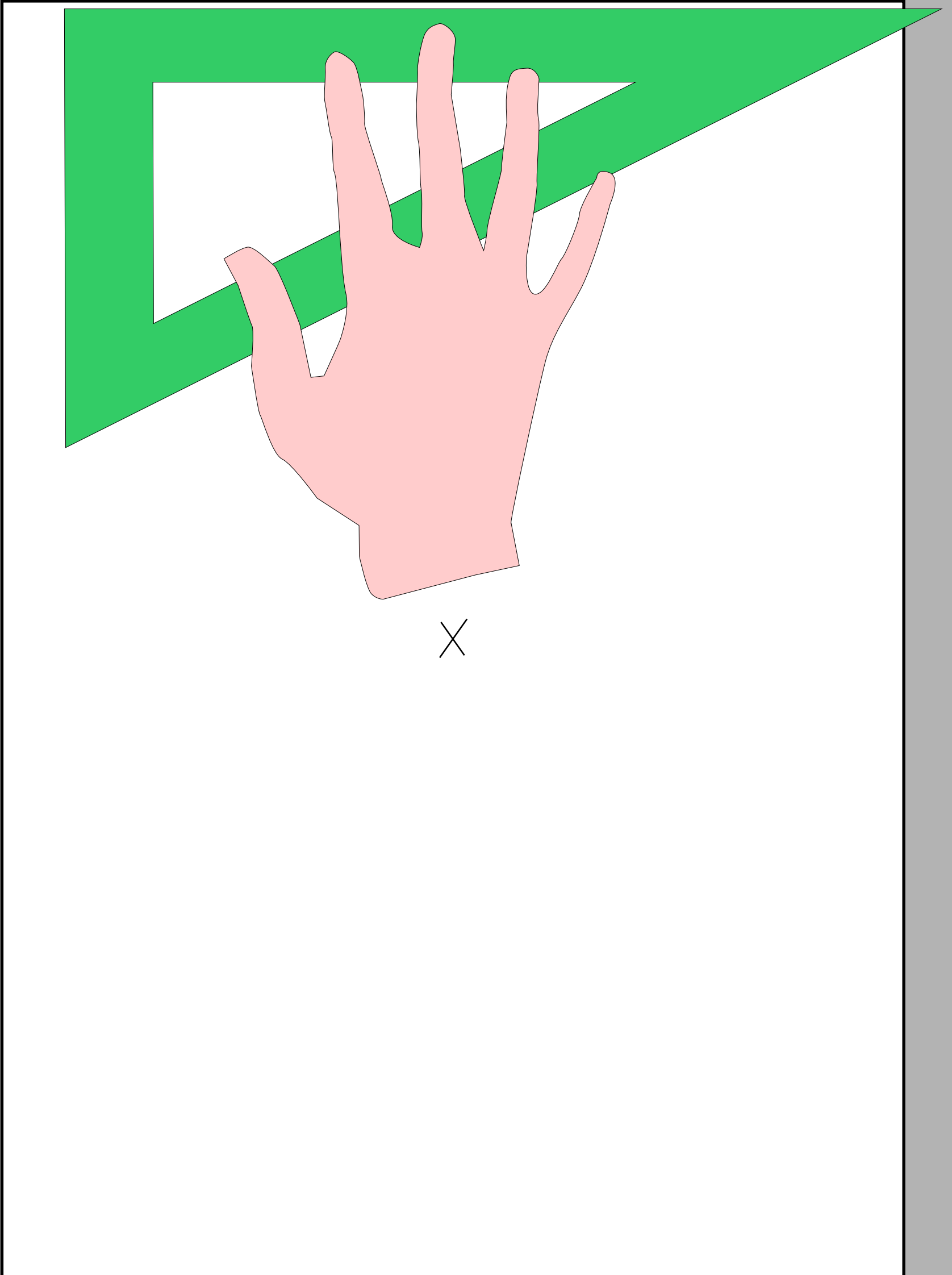

X

MANTENER ALINEADO

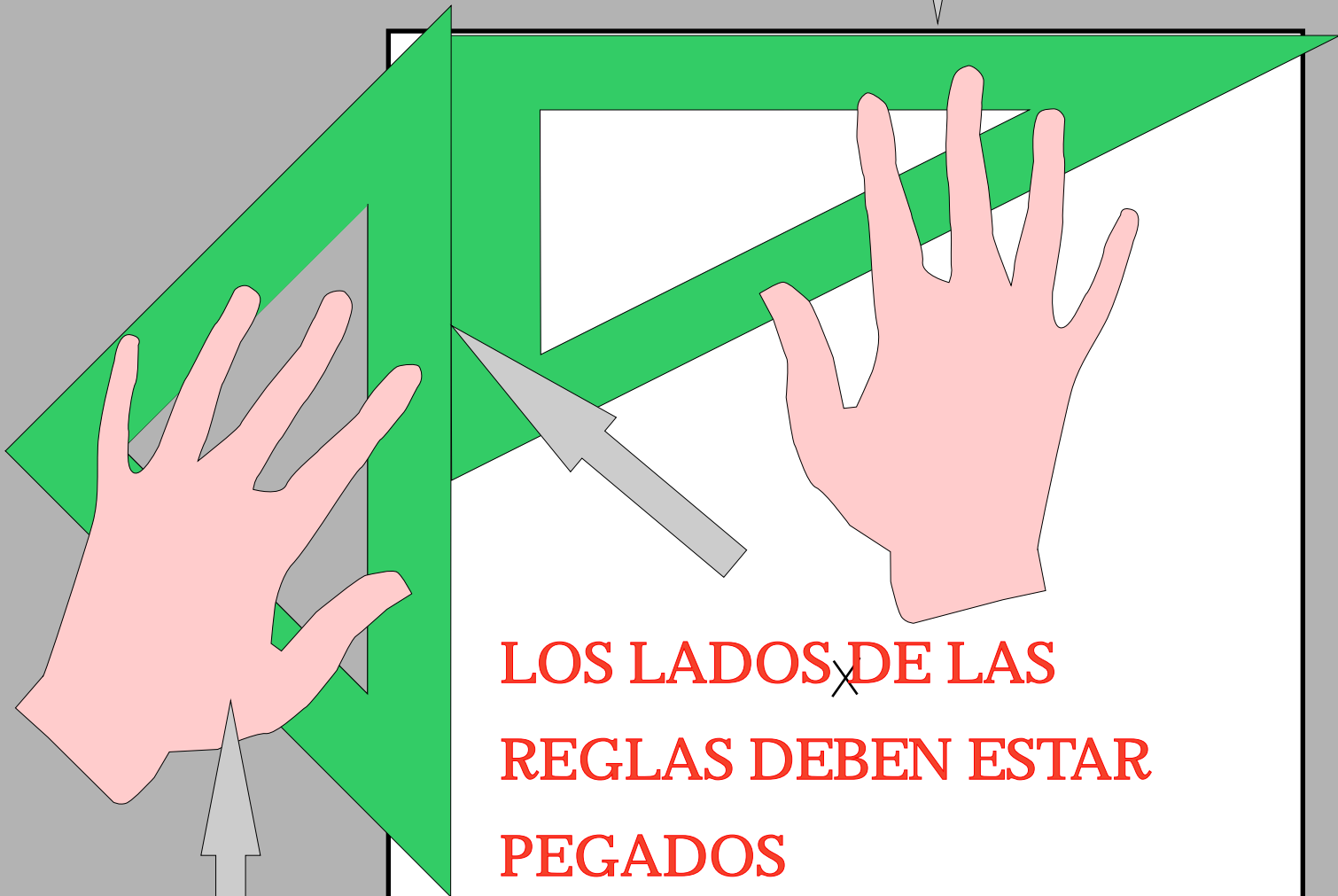

**LOS LADOS DE LAS
REGLAS DEBEN ESTAR
PEGADOS**

**SUJETAR CON FUERZA
PILLANDO EL PAPEL**

DESLIZAR EL CARTABÓN HACIA ABAJO
HASTA QUE VEAMOS EL PUNTO CENTRAL.

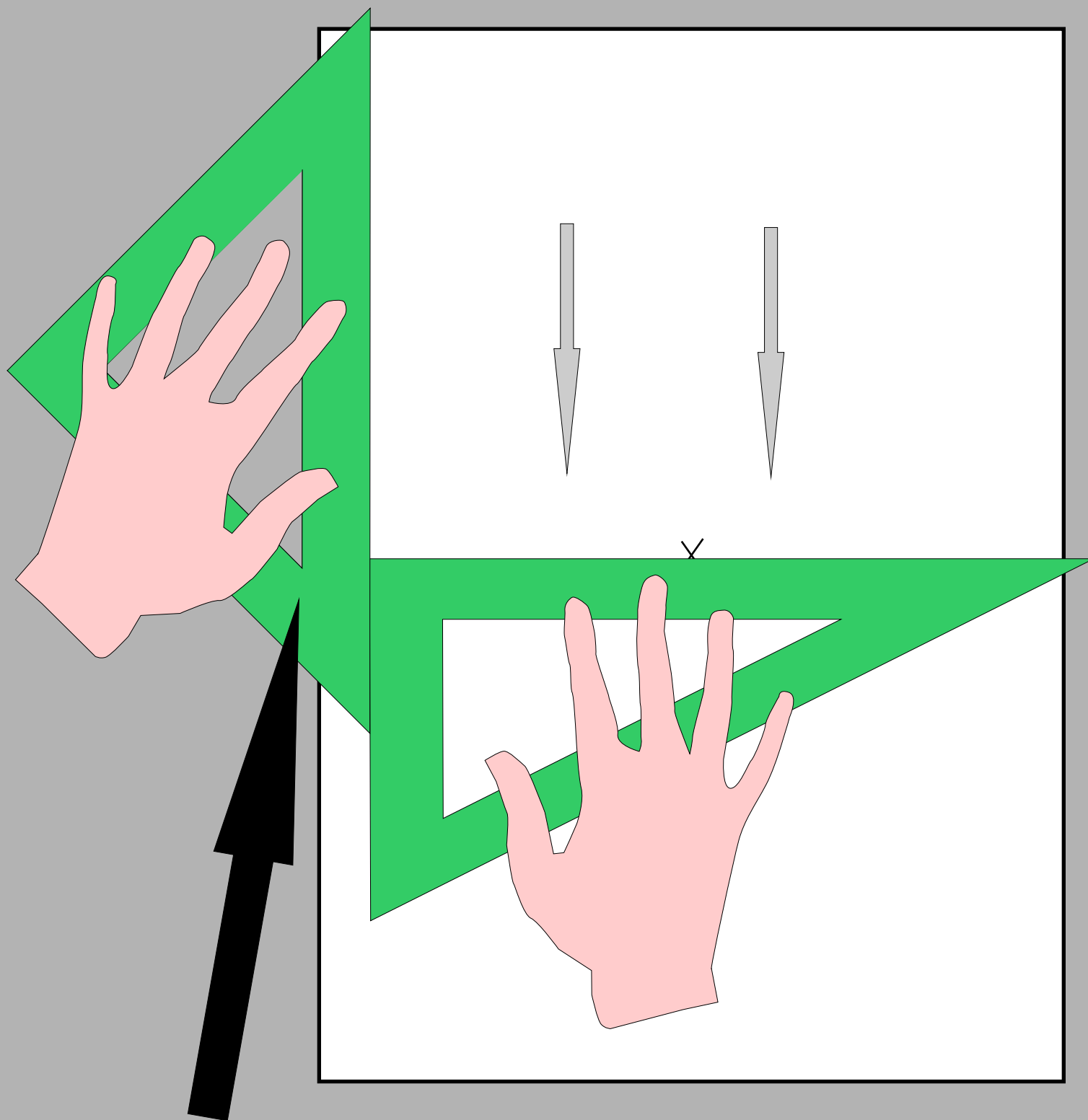

“ESTA REGLA NO DEBE MOVERSE NADA

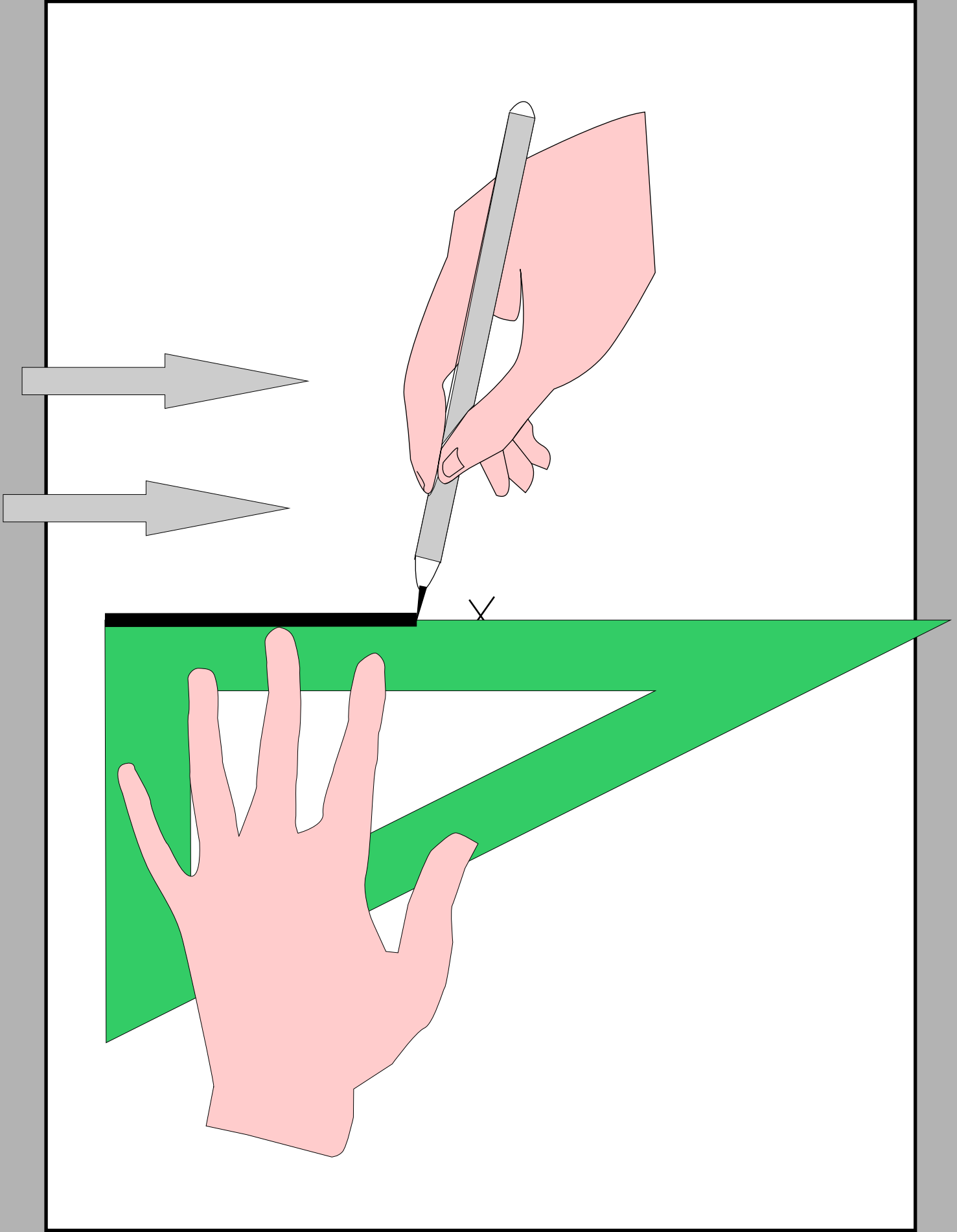

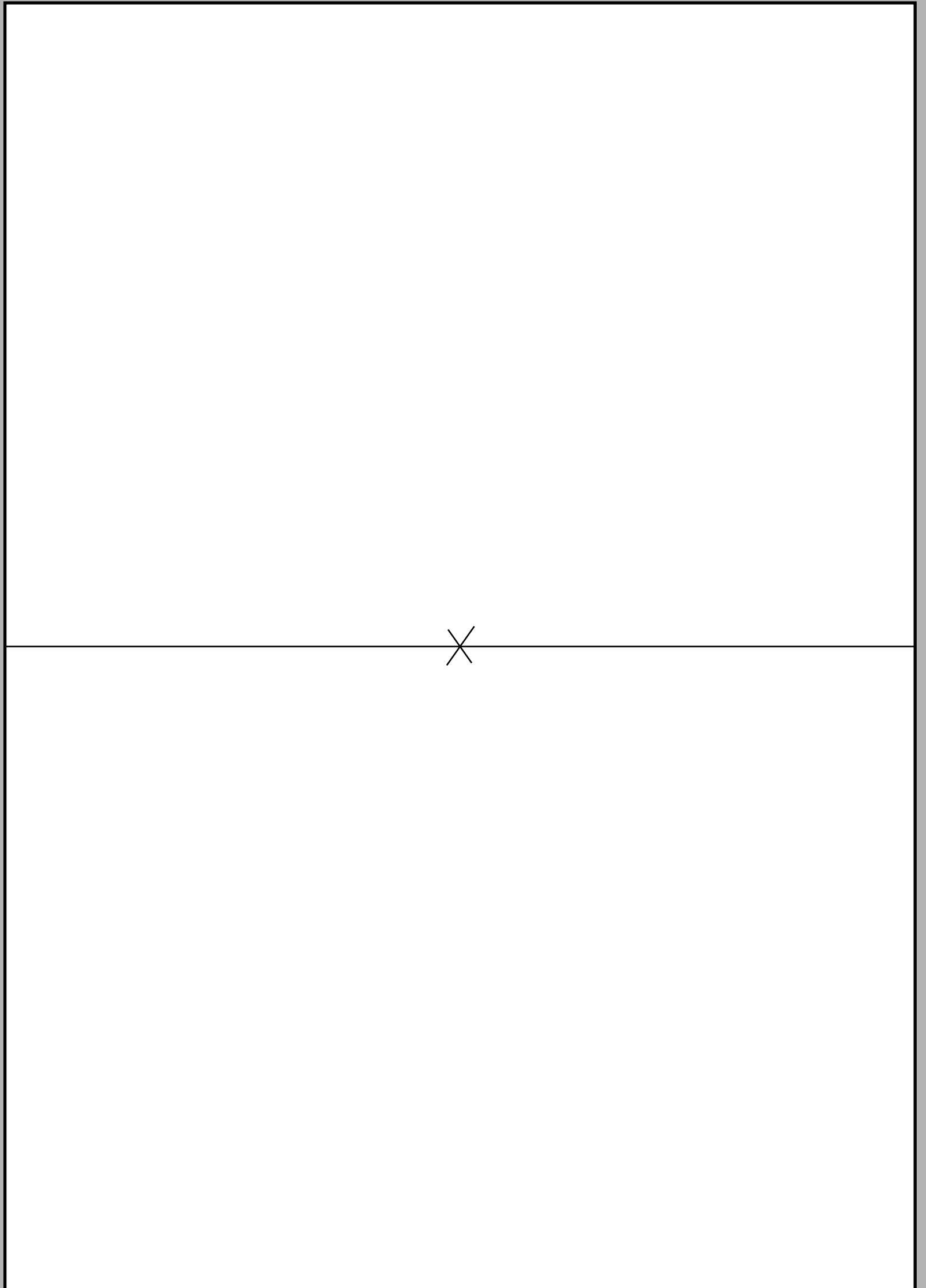

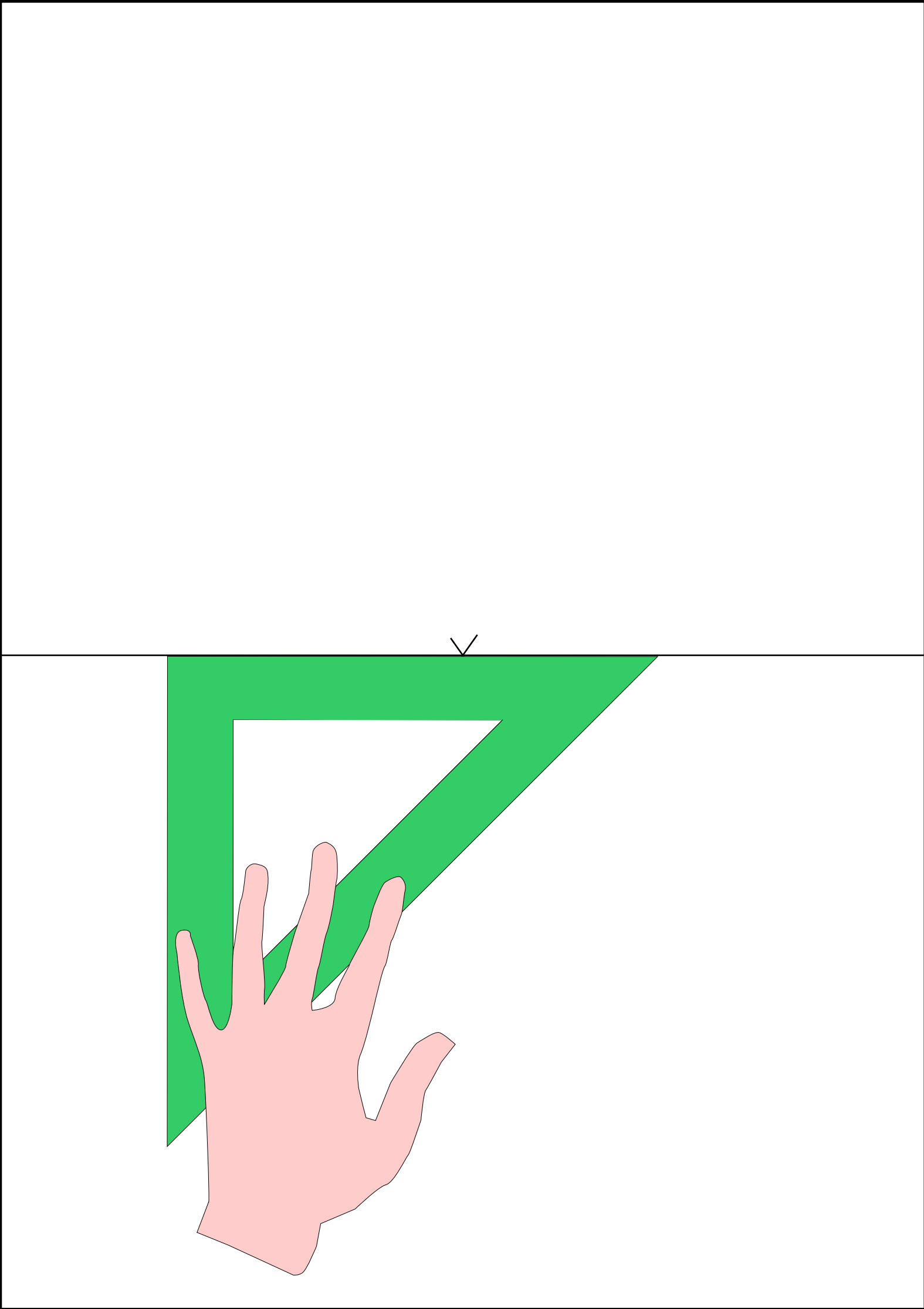

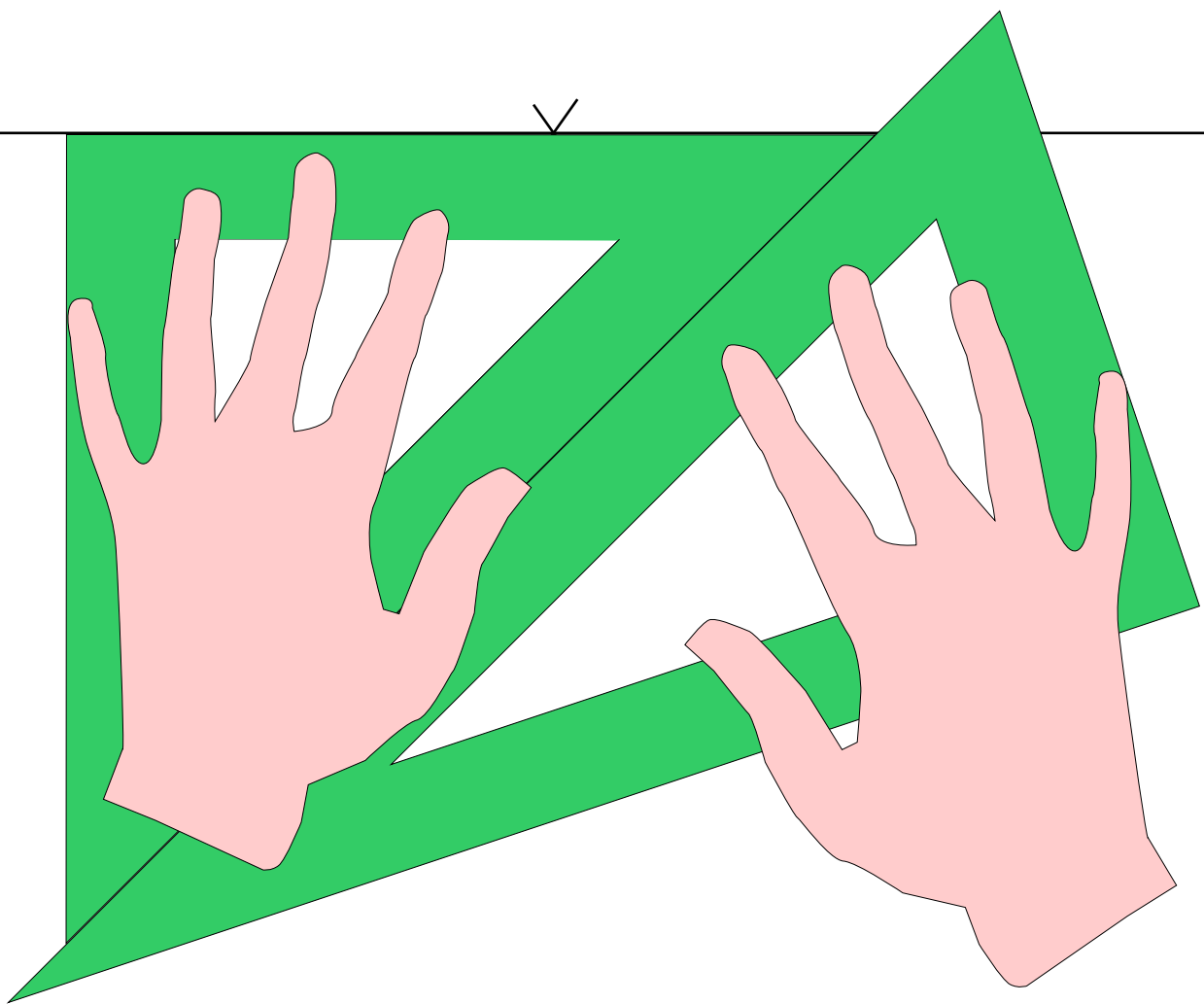

DESLIZAR LA ESCUADRA
HASTA QUE SE VEA EL
PUNTO CENTRAL

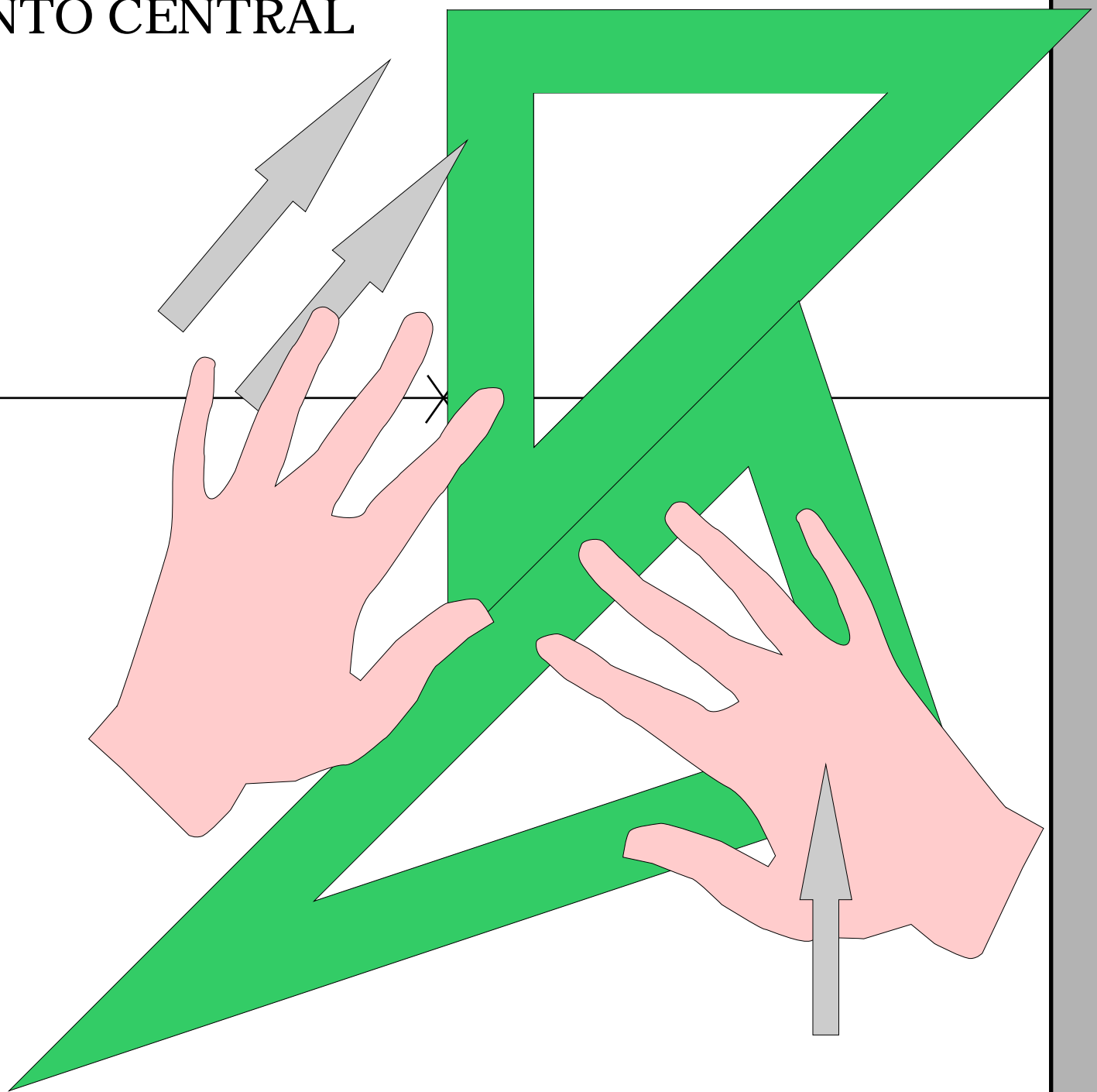

**SUJETAR CON FUERZA
PILLANDO EL PAPEL**

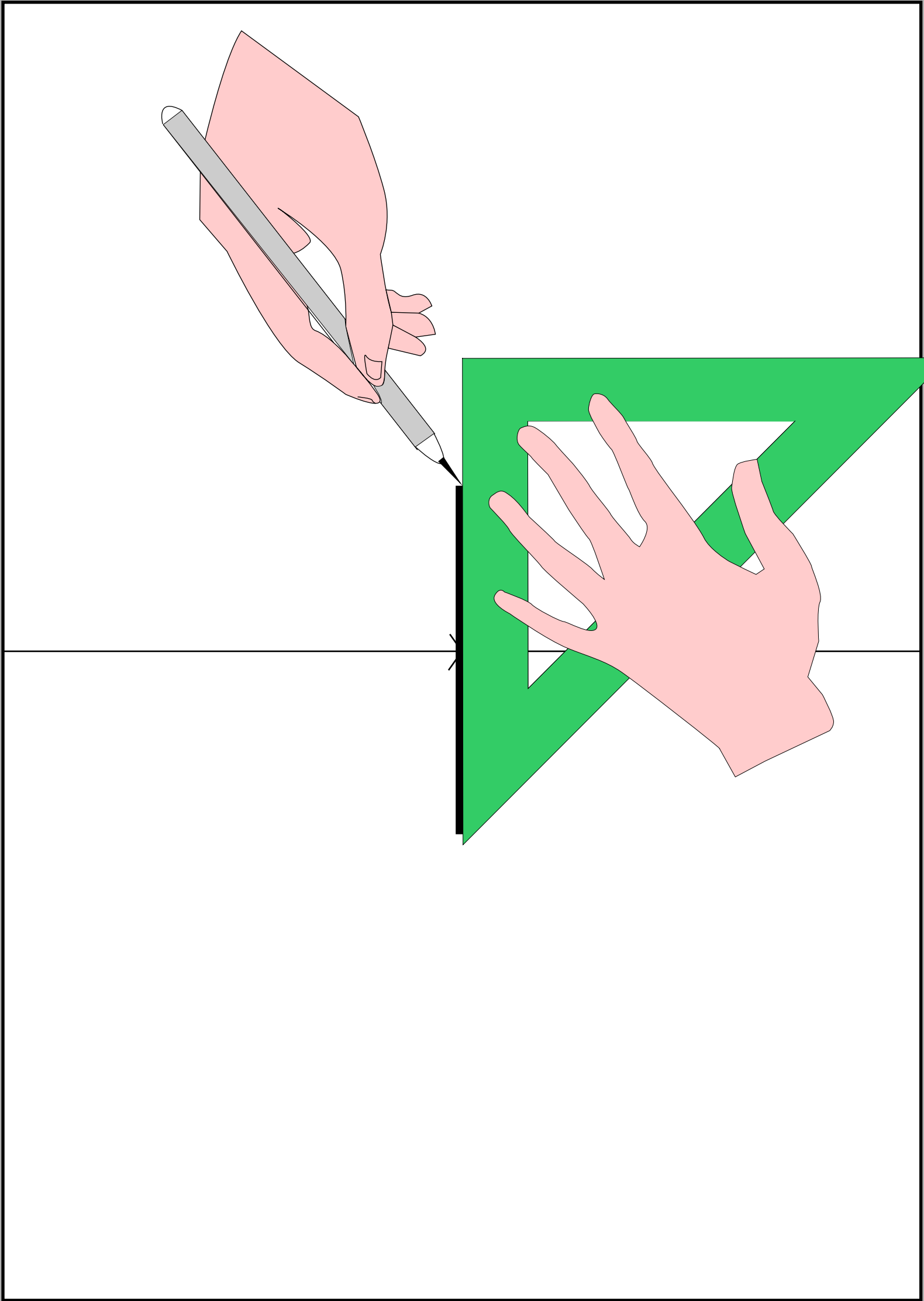

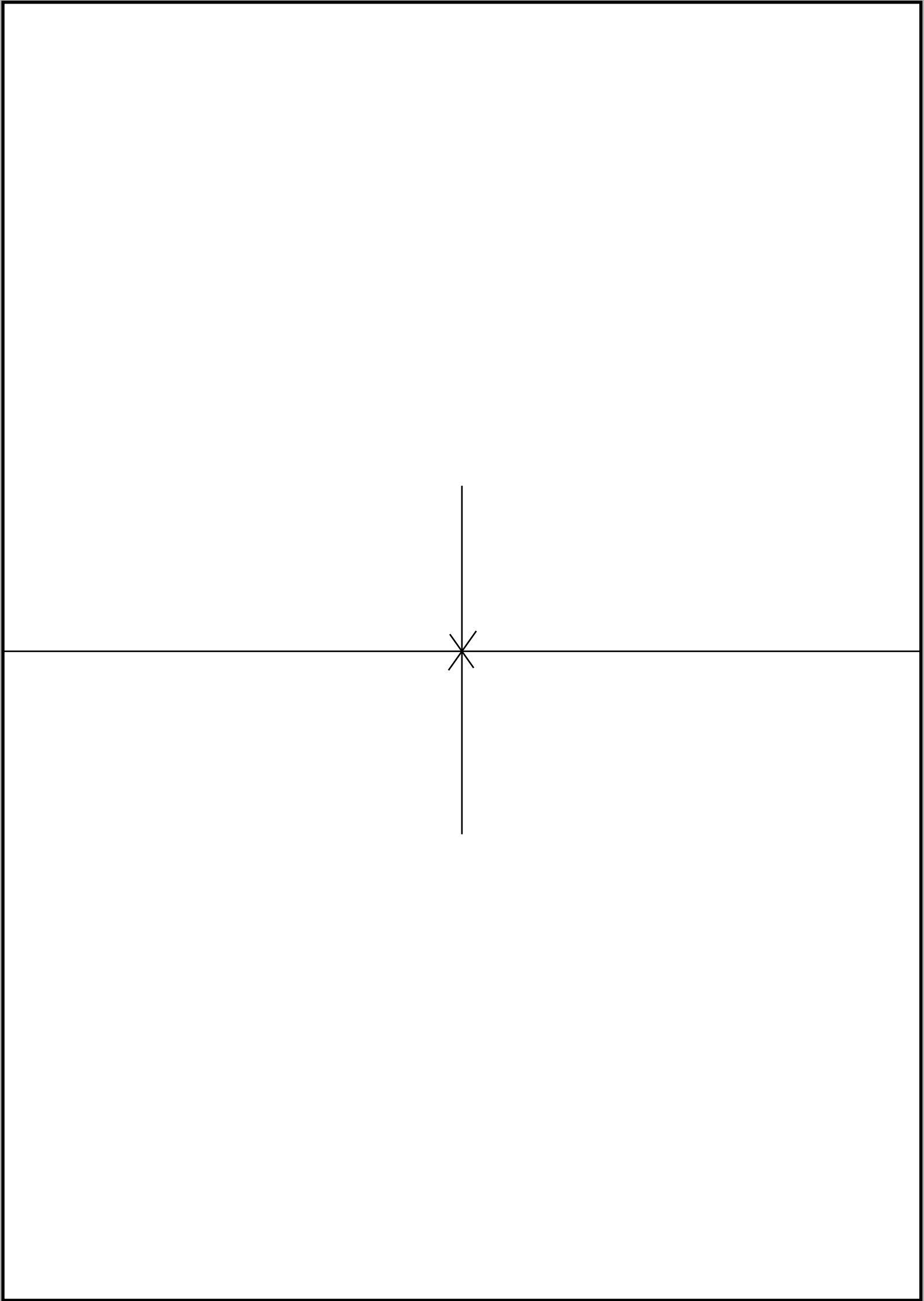

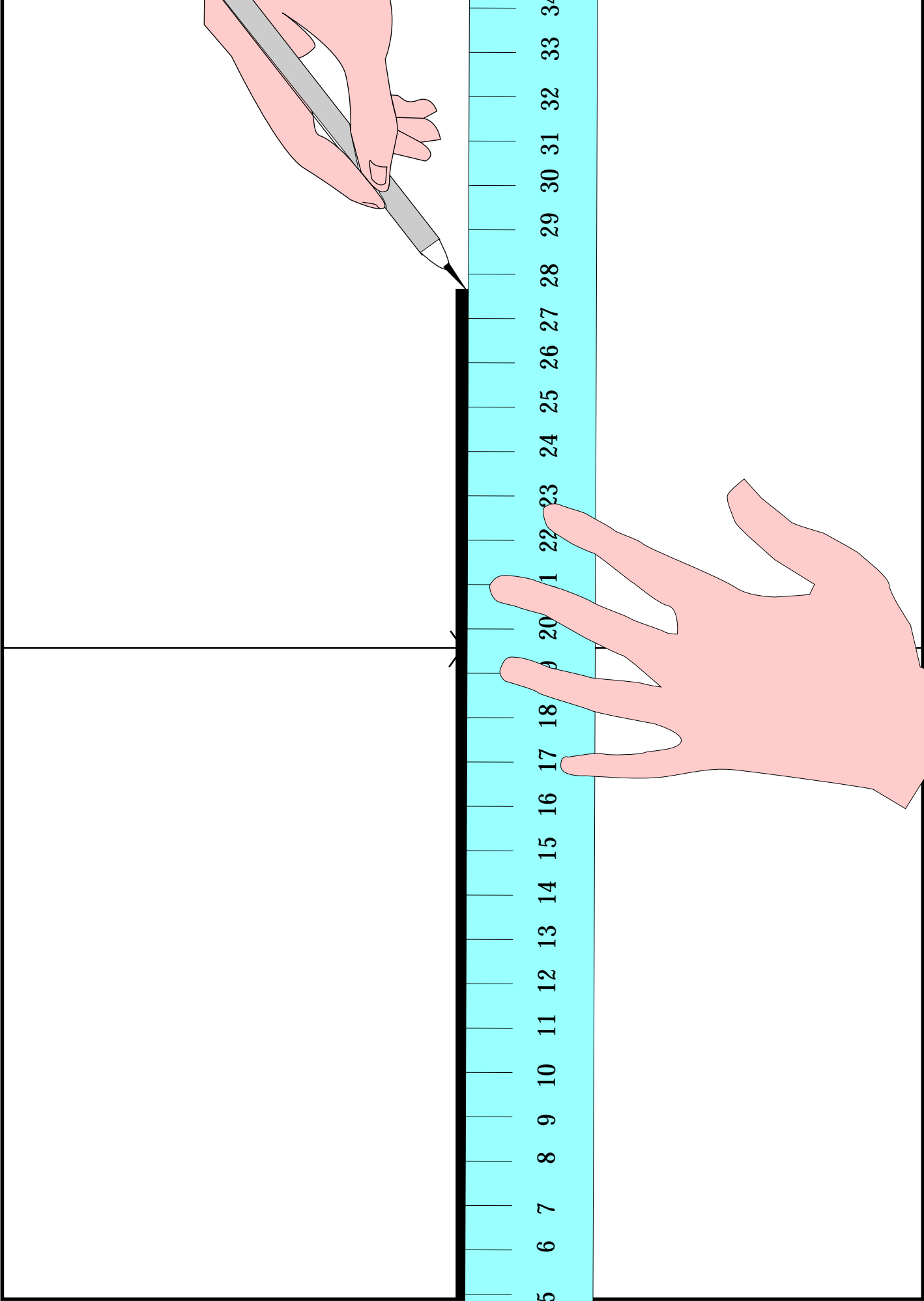

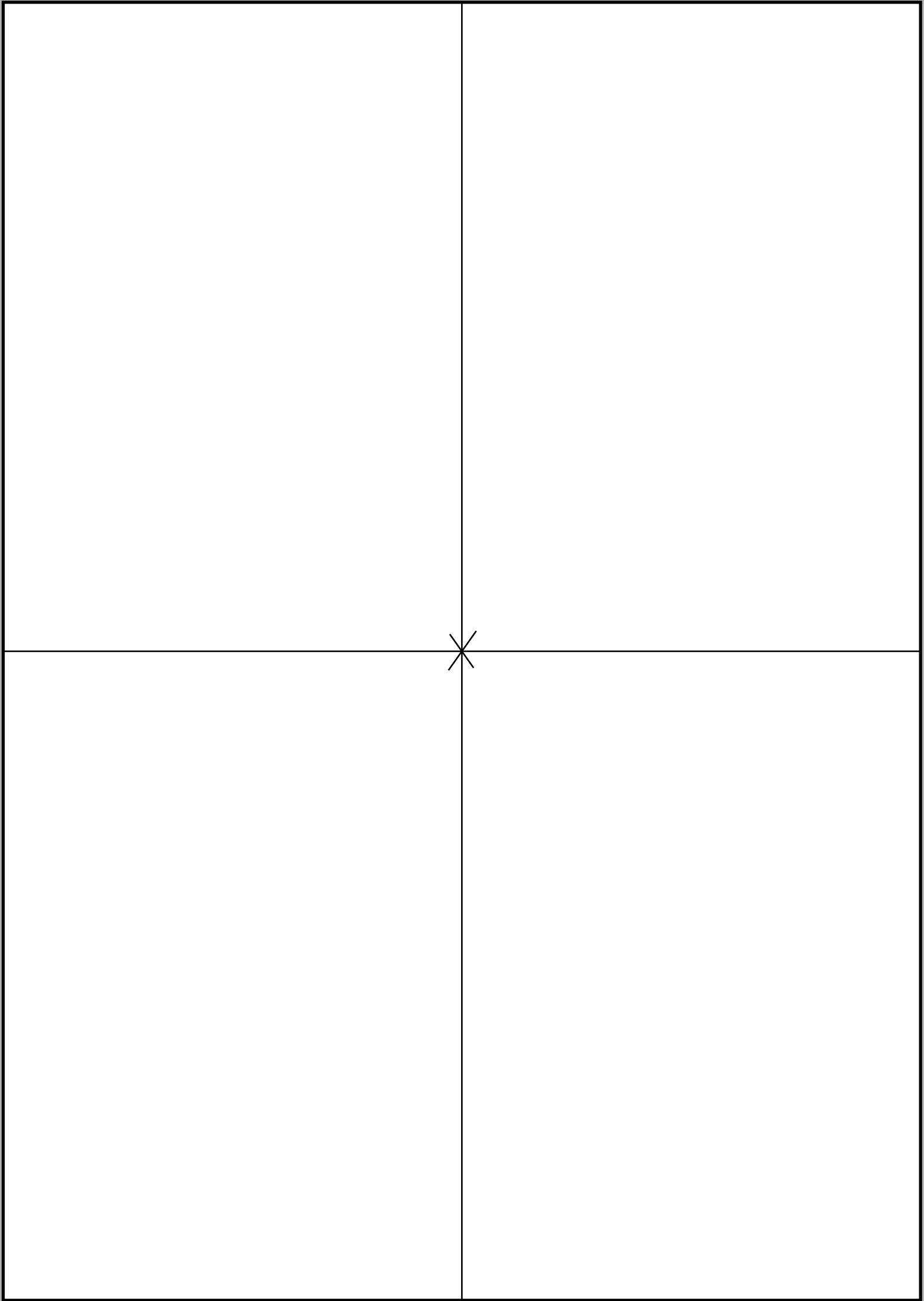

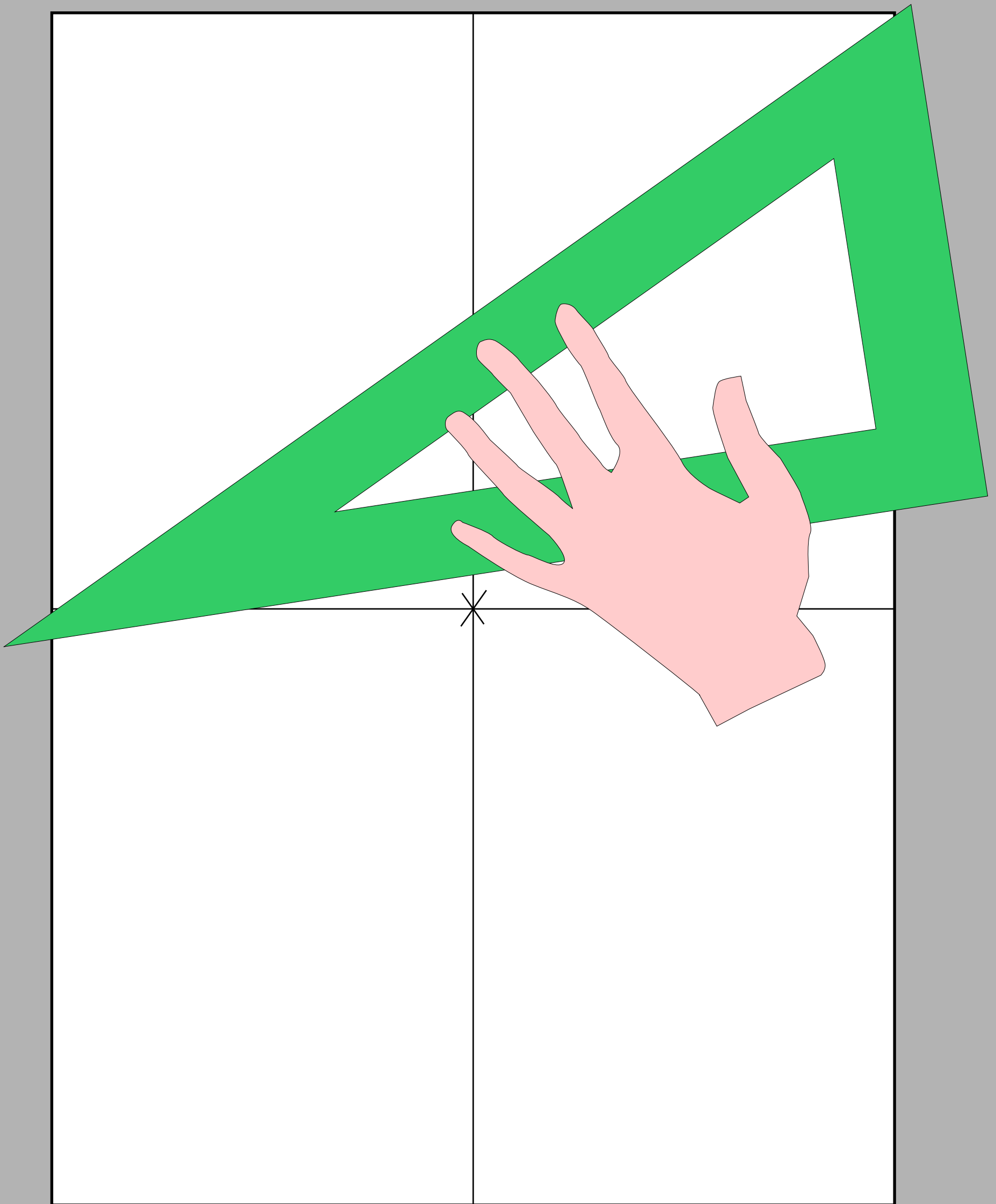

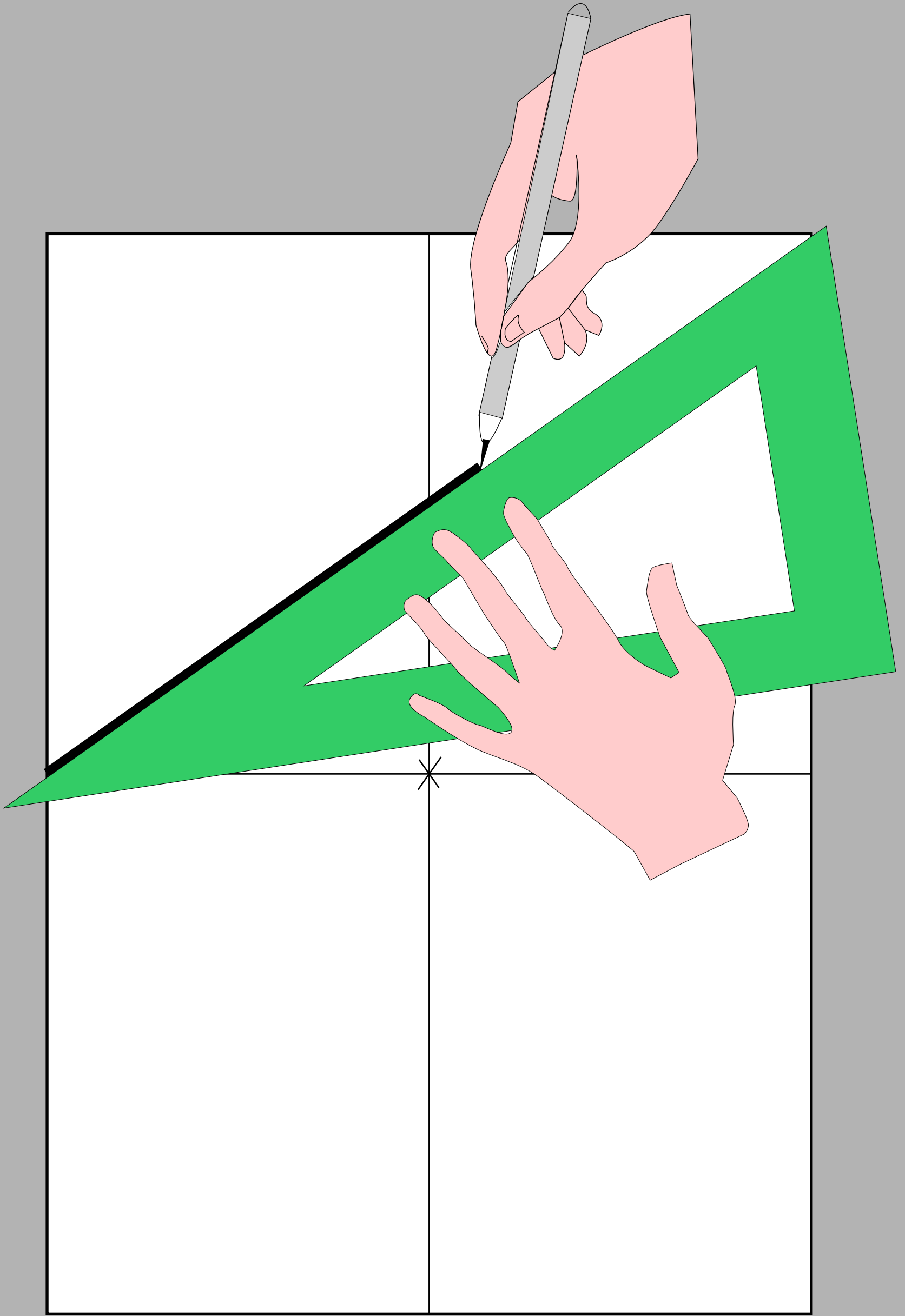

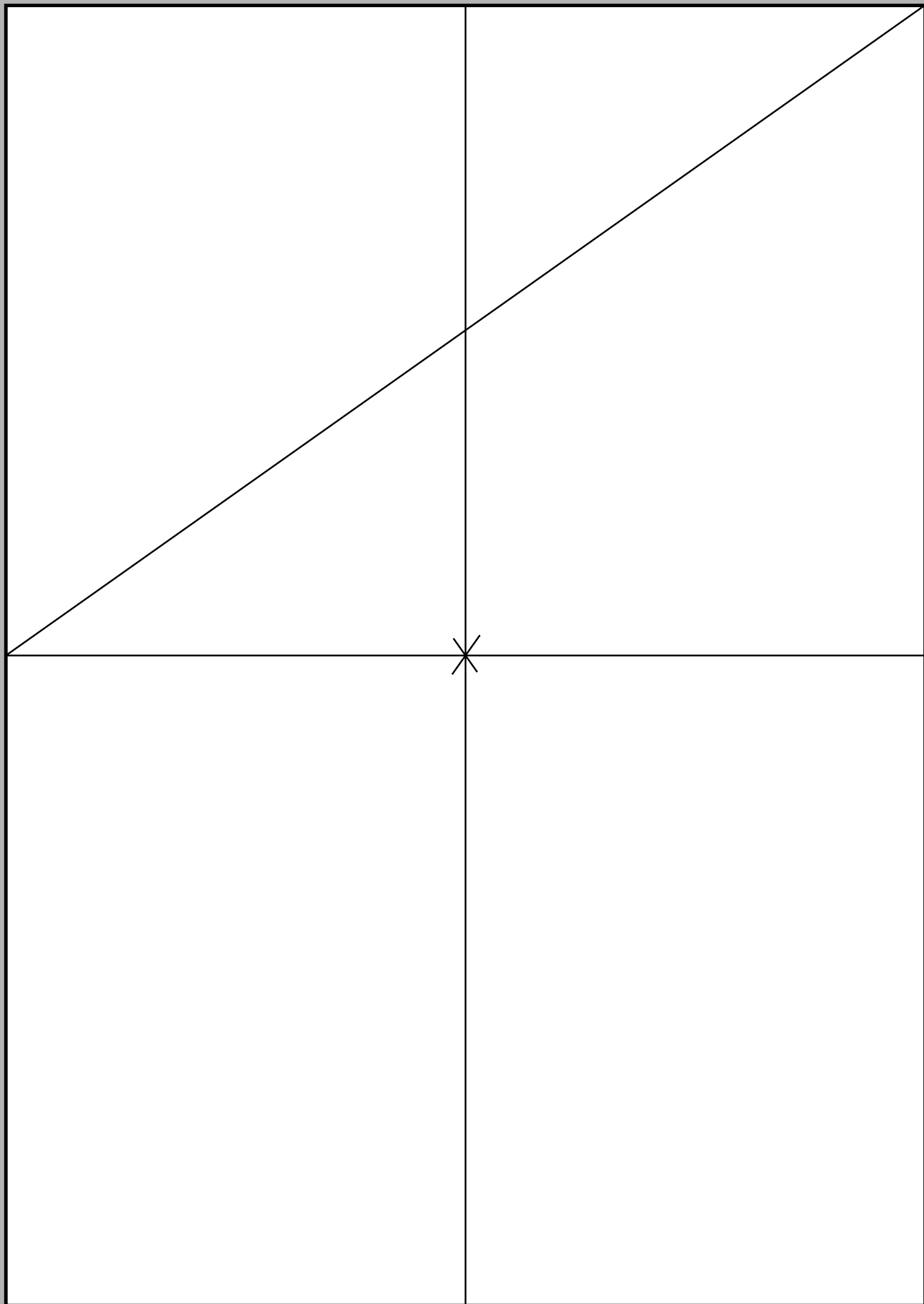

BORRAR ESTA DIAGONAL MENOS
EL PUNTO DE CORTE CON LA
VERTICAL.

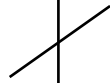

MARCAS A 1 CM
ARRIBA Y ABAJO
DEL PUNTO
CENTRAL,
SOBRE LA
RECTA VERTICAL

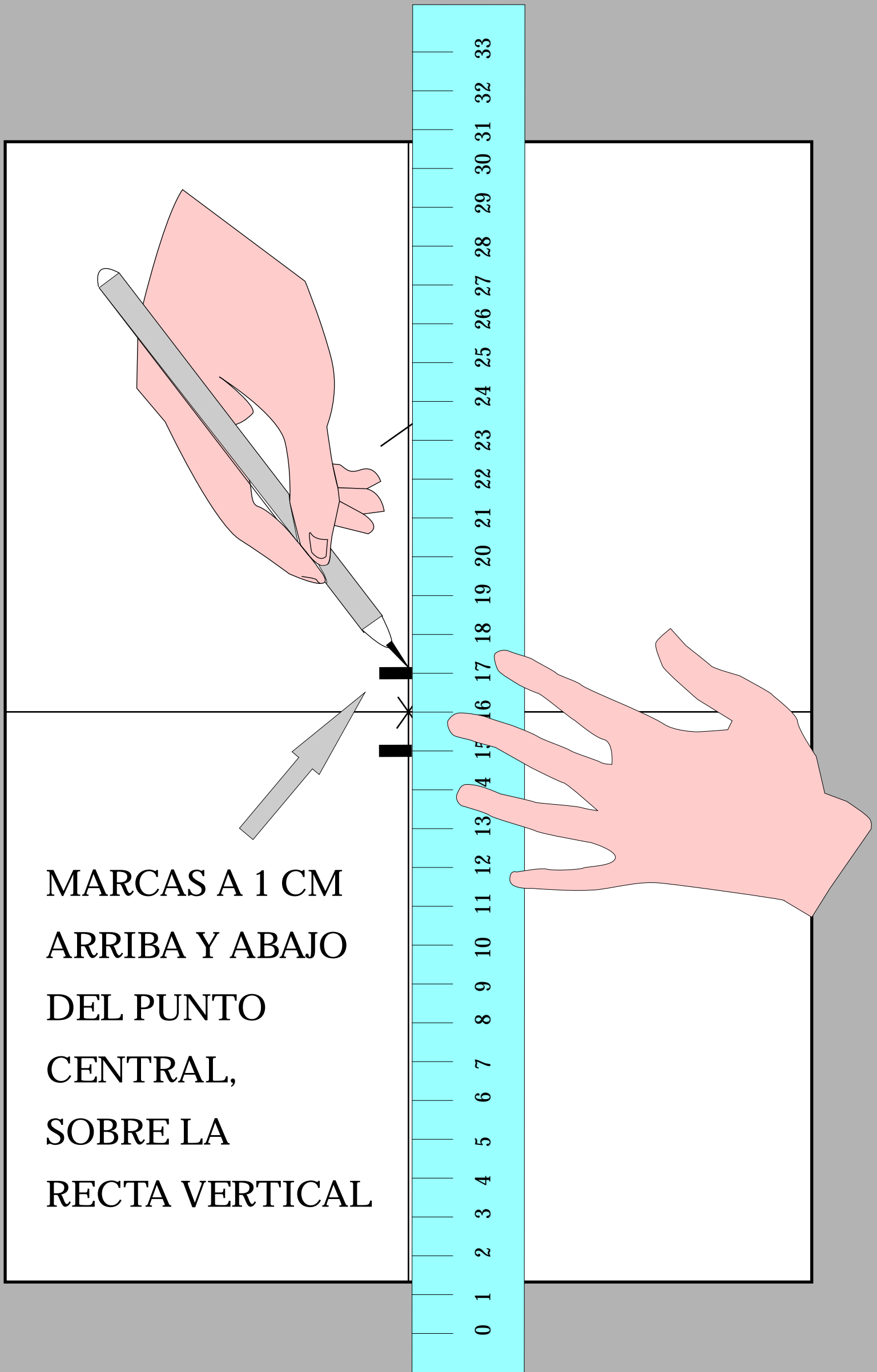

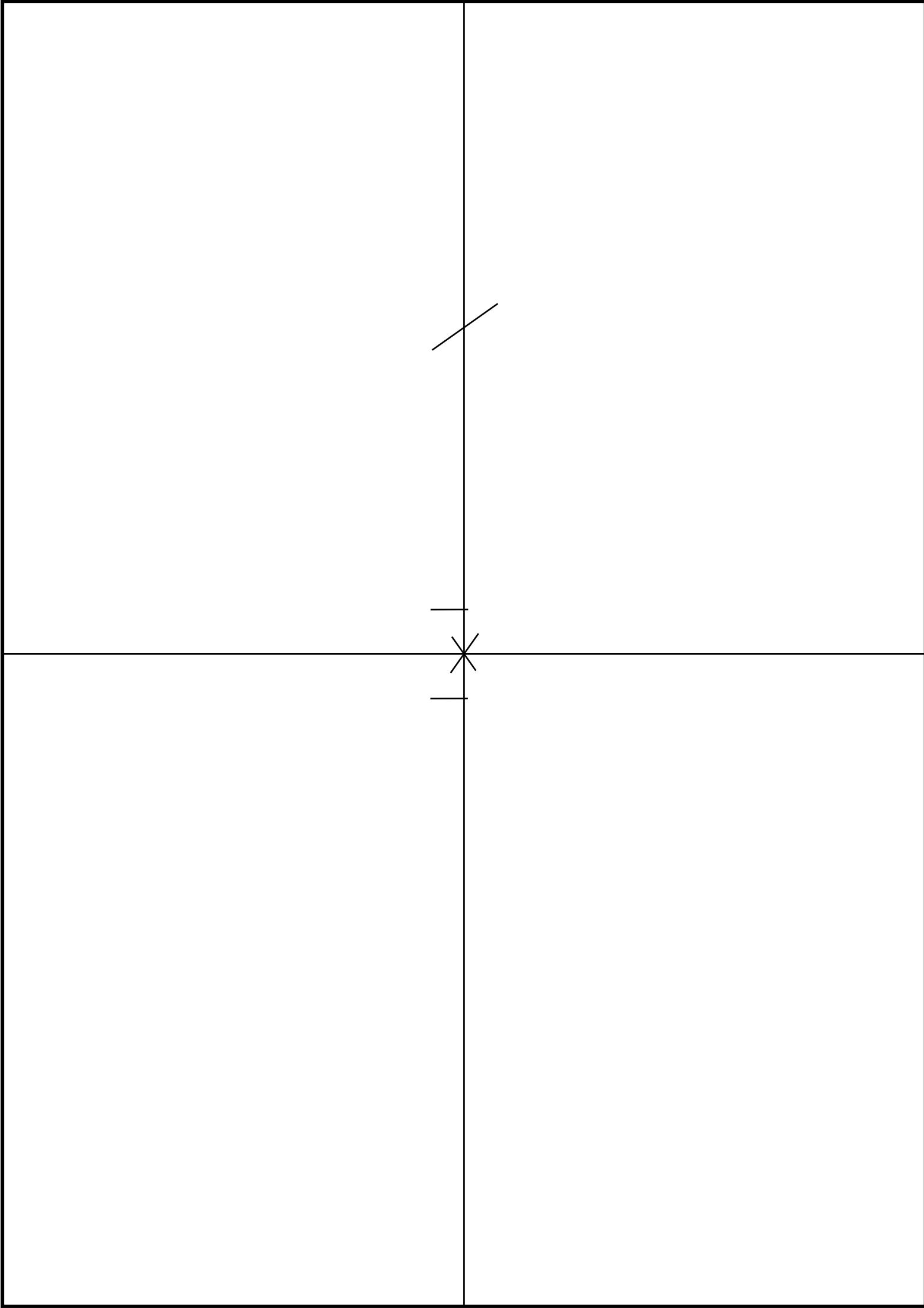

Con el compás, hacemos centro en el punto que acabamos de conseguir, y abrimos hasta la marca que está a 1 cm por encima del centro del papel.

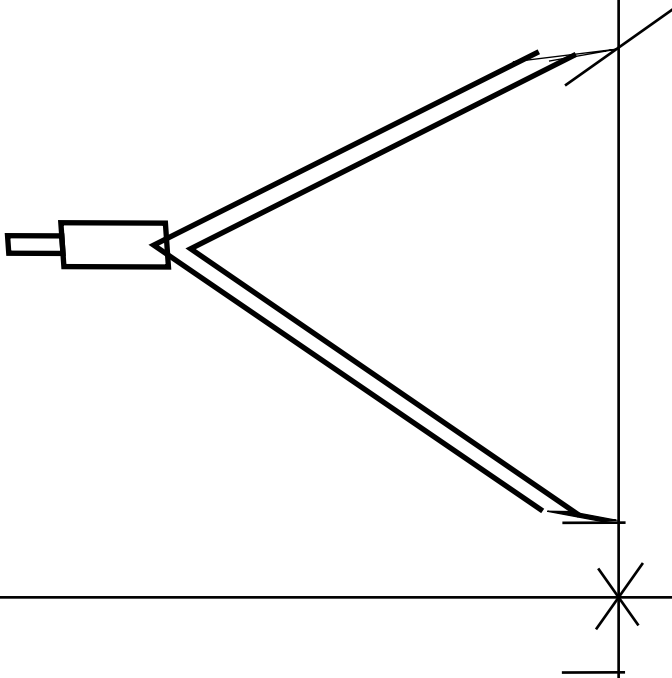

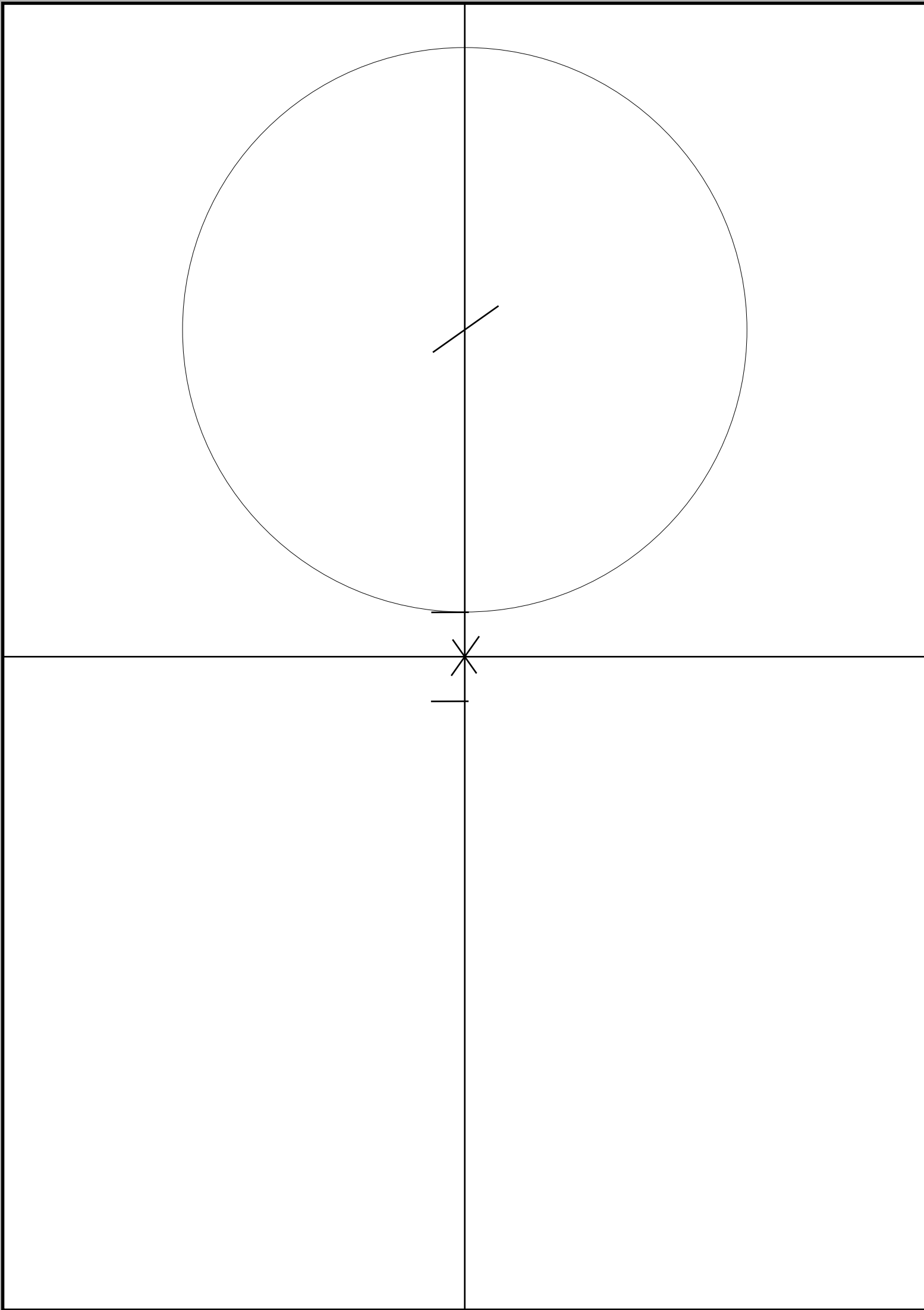

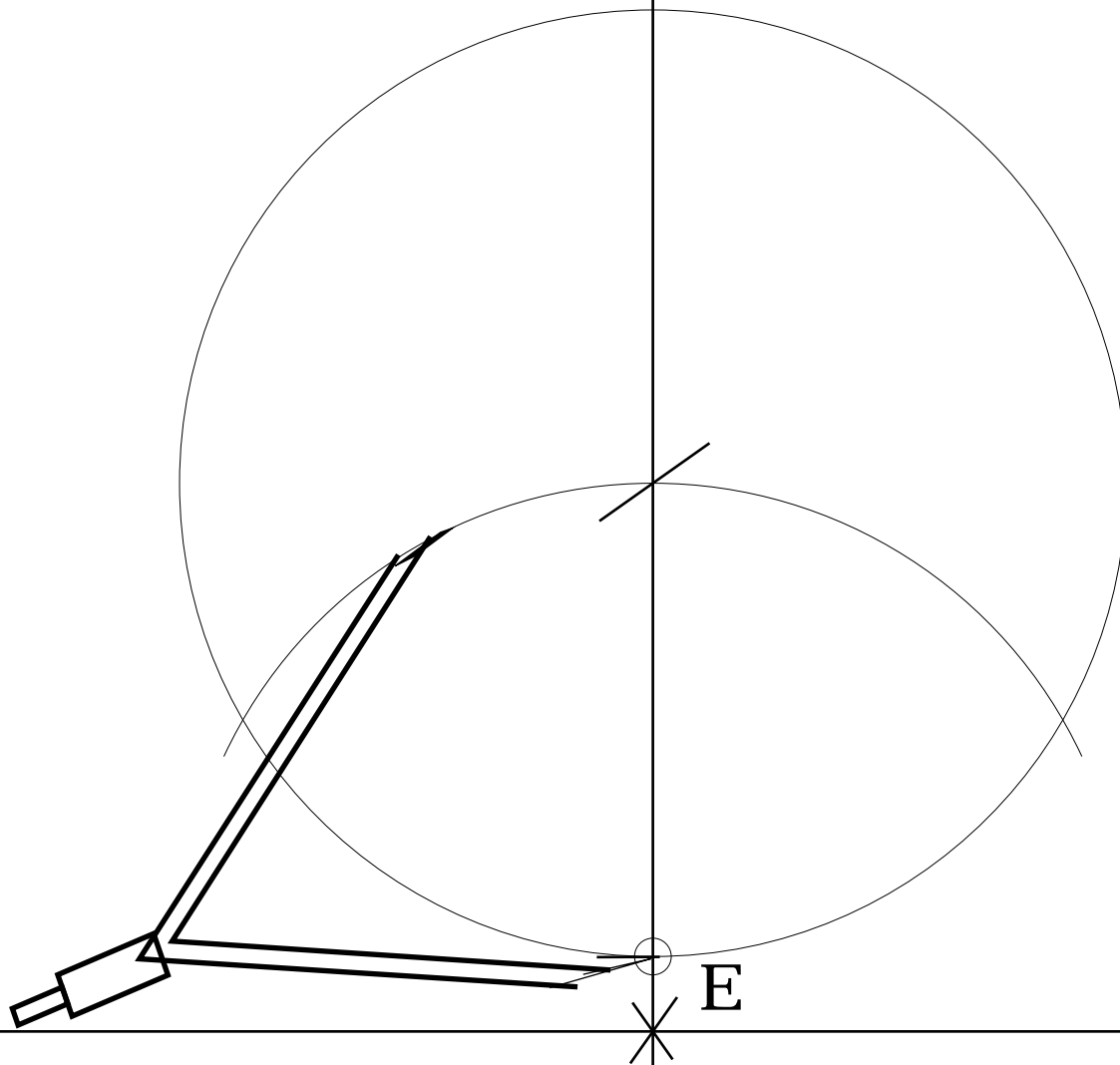

Con el mismo radio, dibujamos un arco grande pinchando en el punto E.

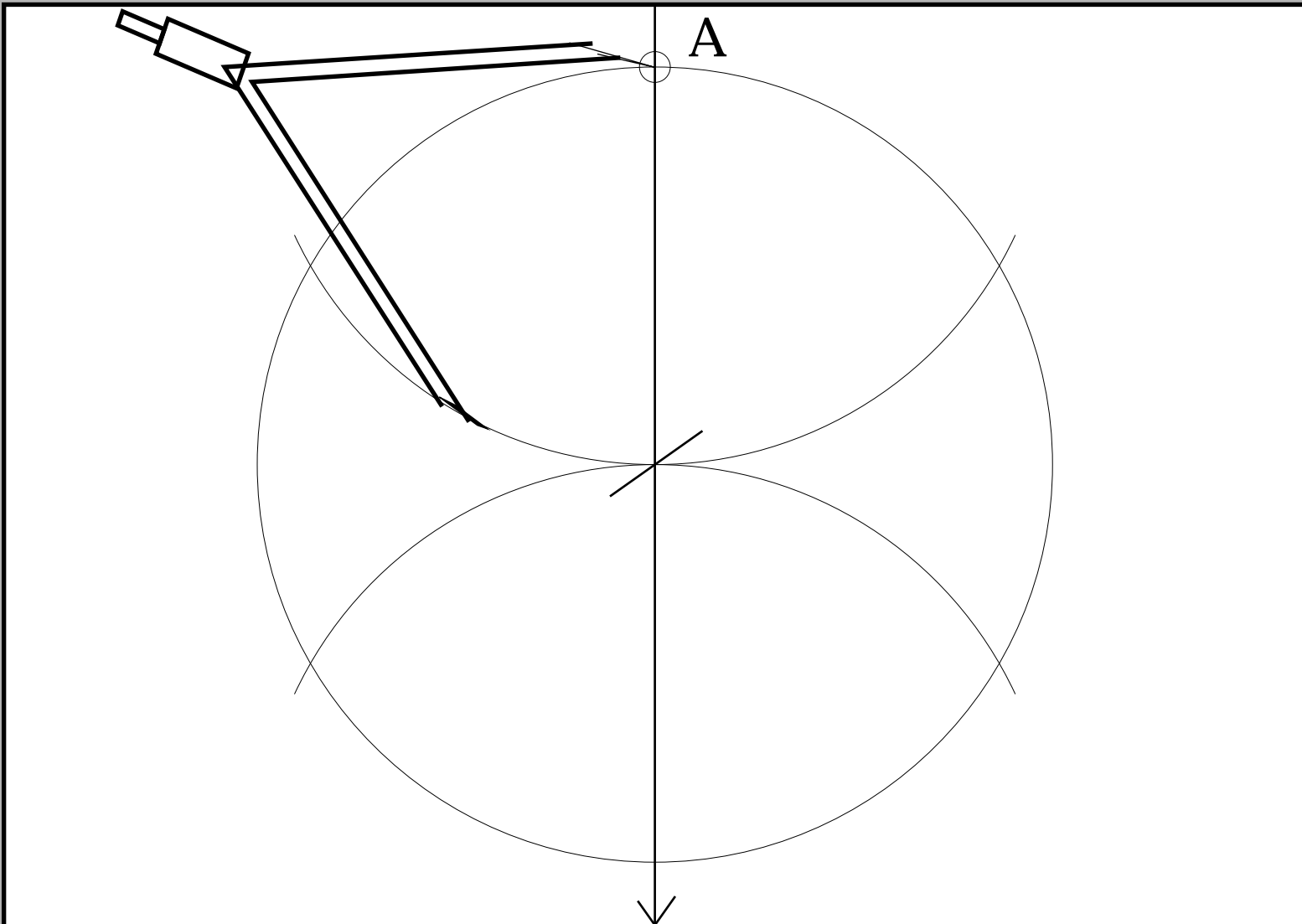

Hacemos lo mismo pinchando en el punto A.
Los dos arcos deben pasar exactamente por
el centro de la circunferencia.

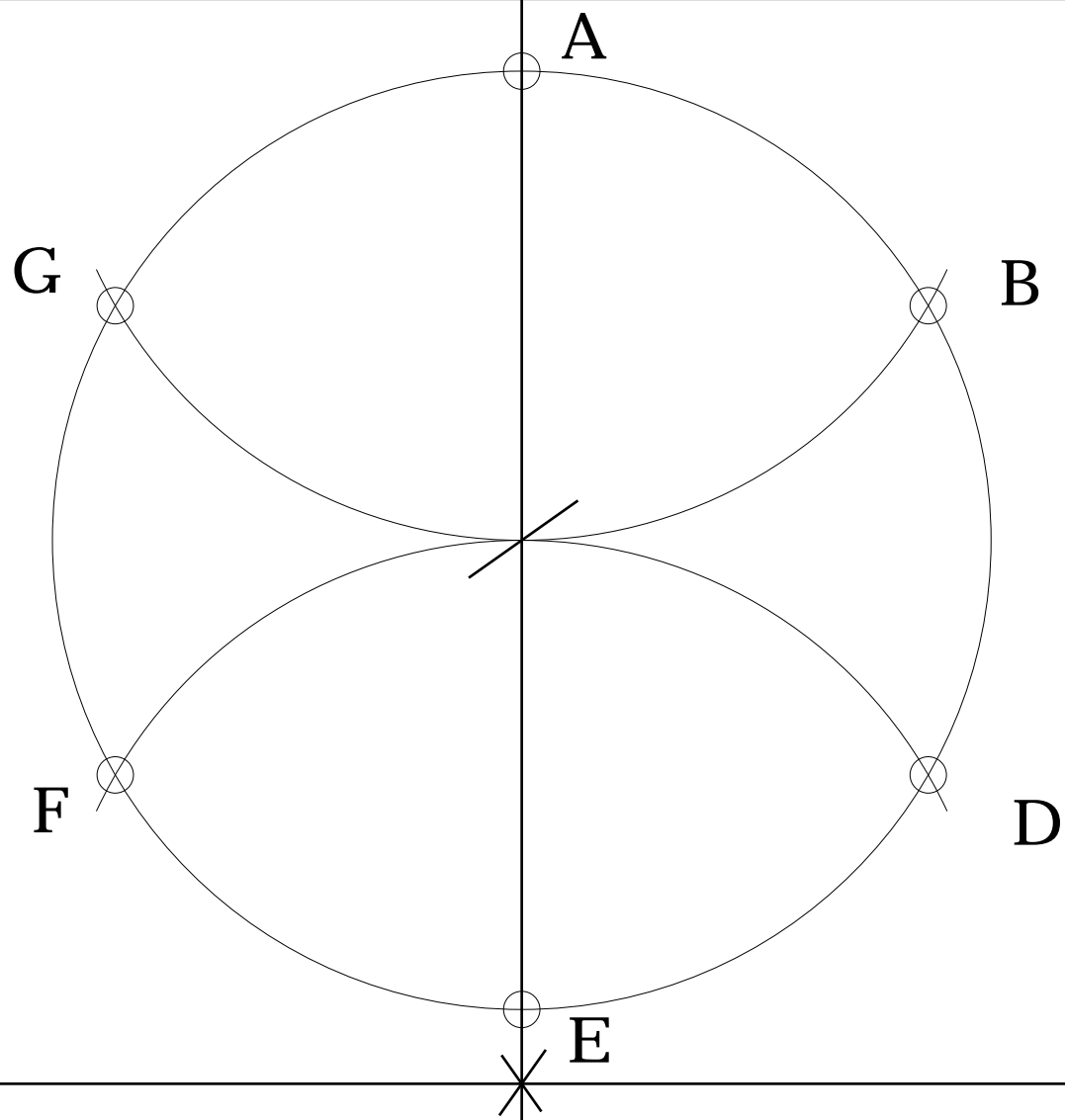

HEMOS DIVIDIDO LA CIRCUNFERENCIA
EN SEIS PARTES IGUALES.

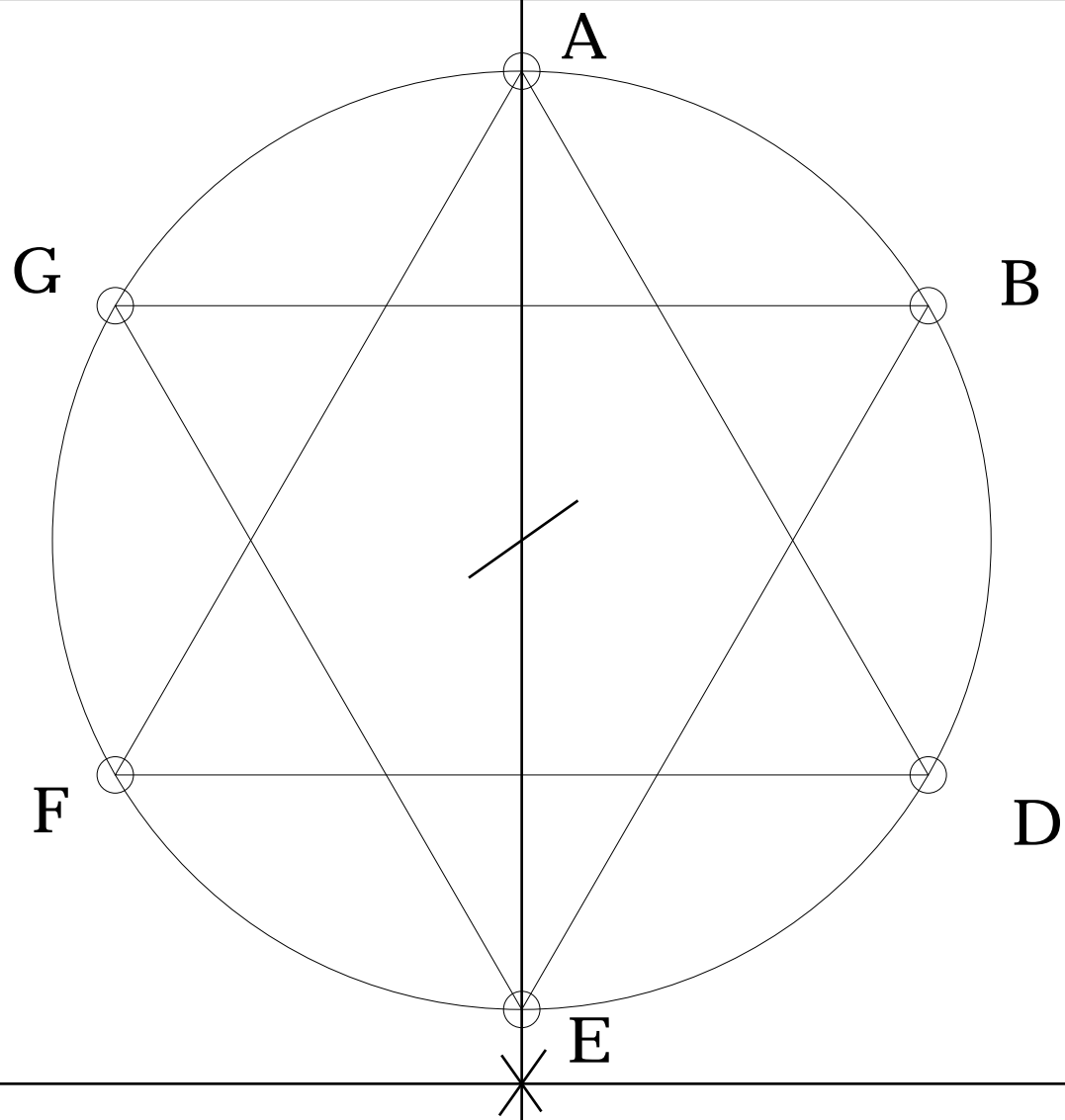

Unimos ahora los puntos A, D y F, y borramos los arcos interiores.

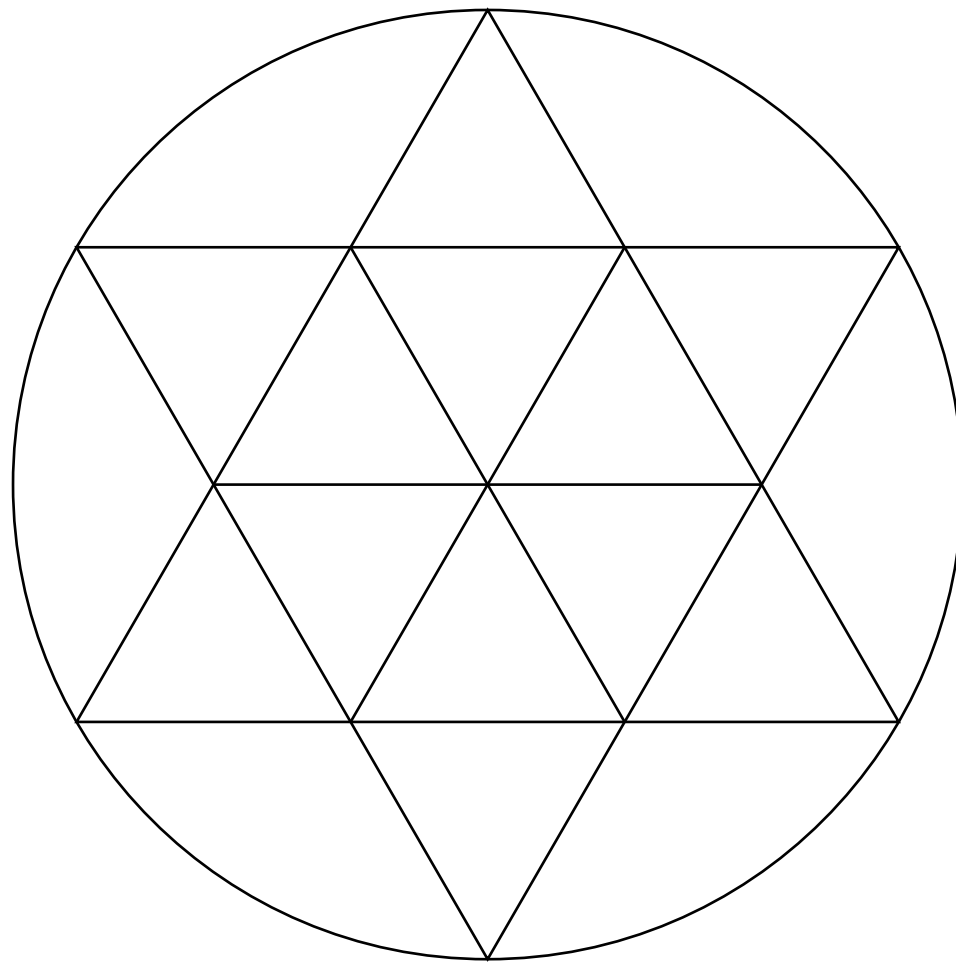

Dibujamos las diagonales del hexágono interior que hemos conseguido, y borramos el diámetro vertical.

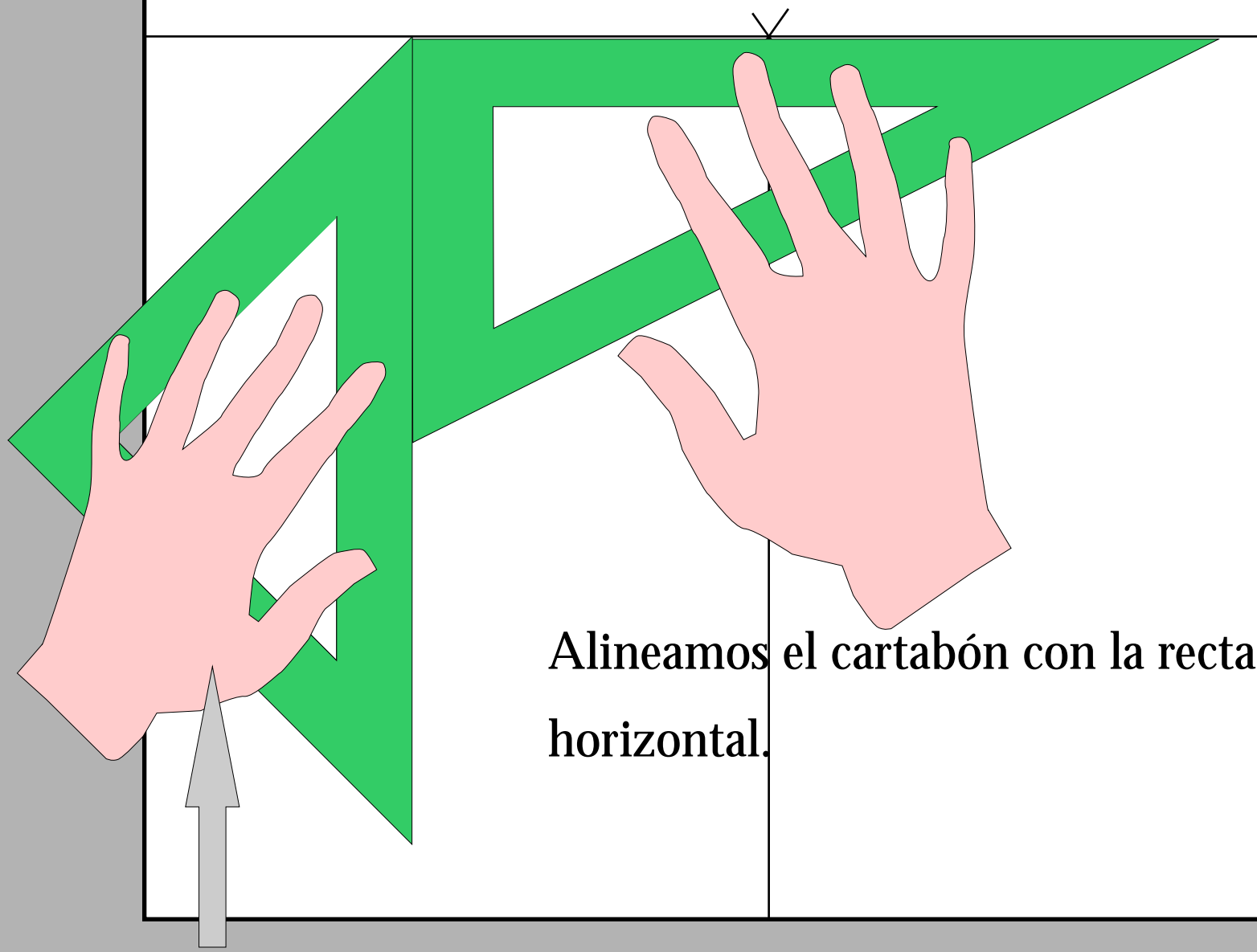
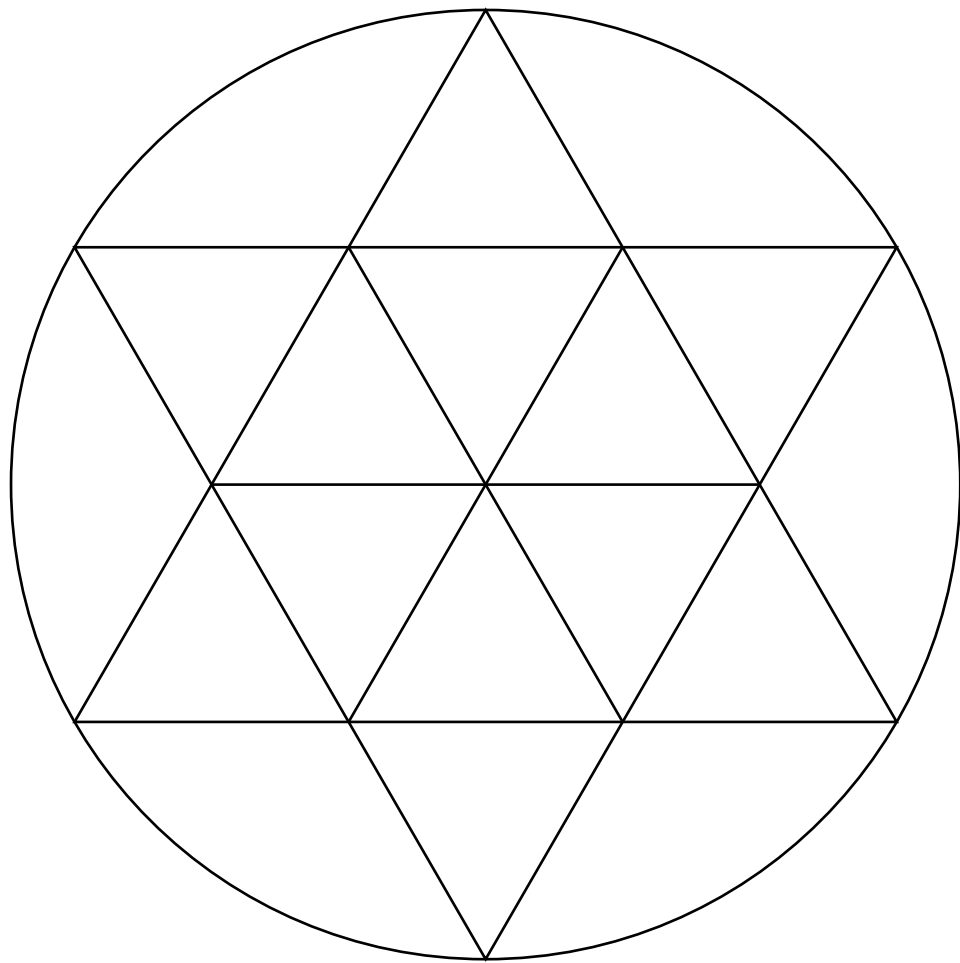

Alineamos el cartabón con la recta horizontal.

SUJETAR CON FUERZA

PILLANDO EL PAPEL

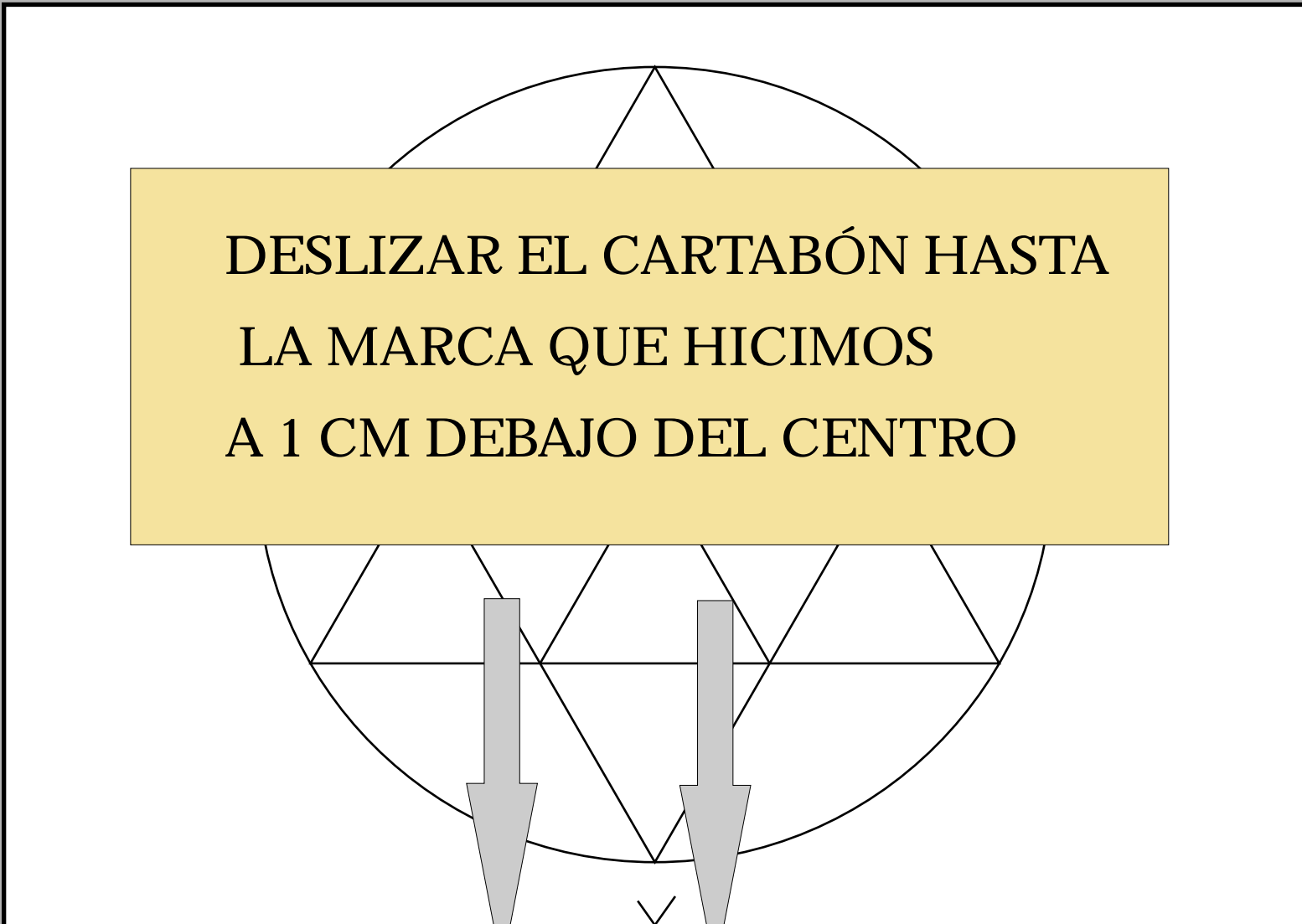

DESLIZAR EL CARTABÓN HASTA
LA MARCA QUE HICIMOS
A 1 CM DEBAJO DEL CENTRO

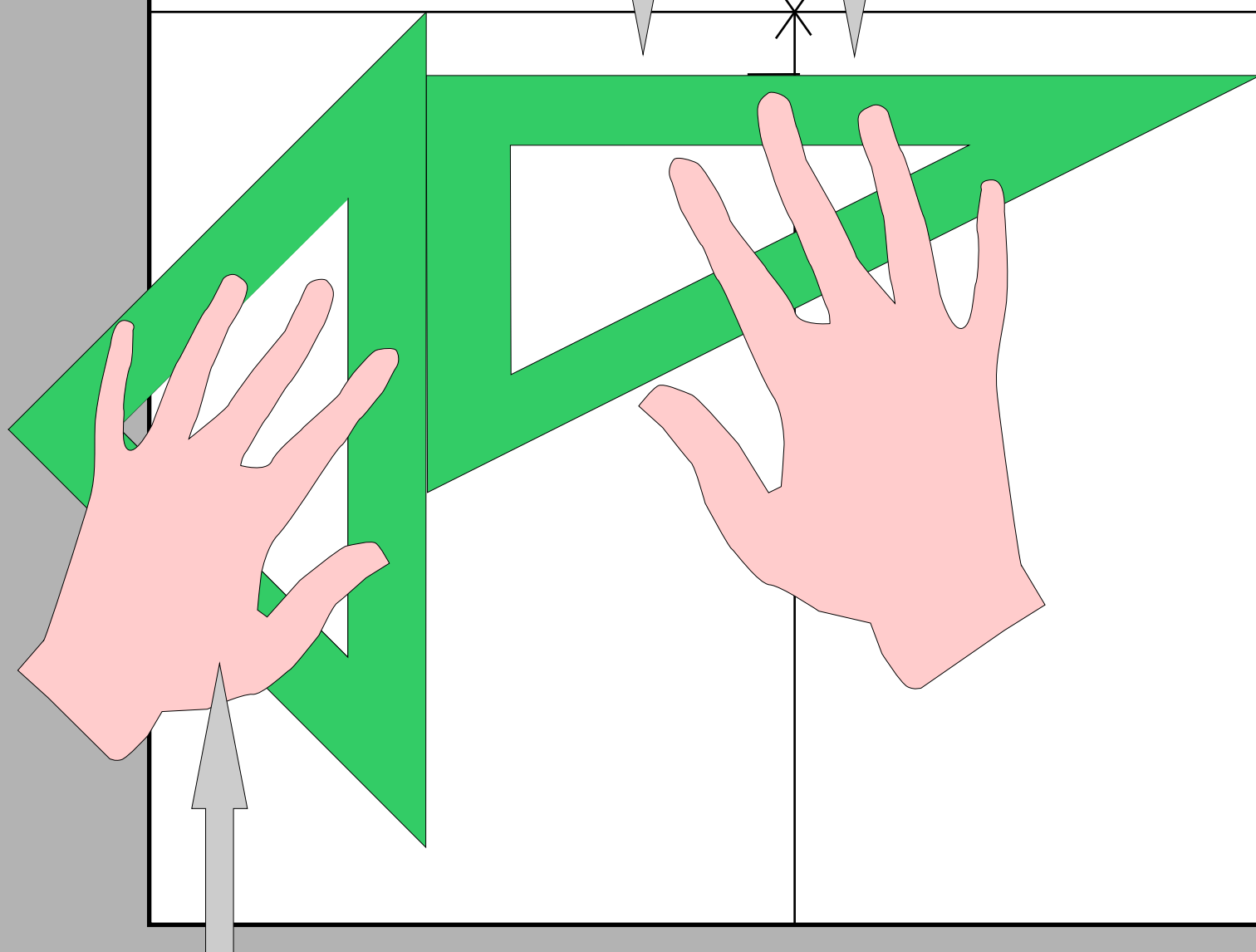

SUJETAR CON FUERZA
PILLANDO EL PAPEL

TRAZAR UNA RECTA PARALELA A LA
HORIZONTAL QUE PASABA POR EL
CENTRO DEL PAPEL.

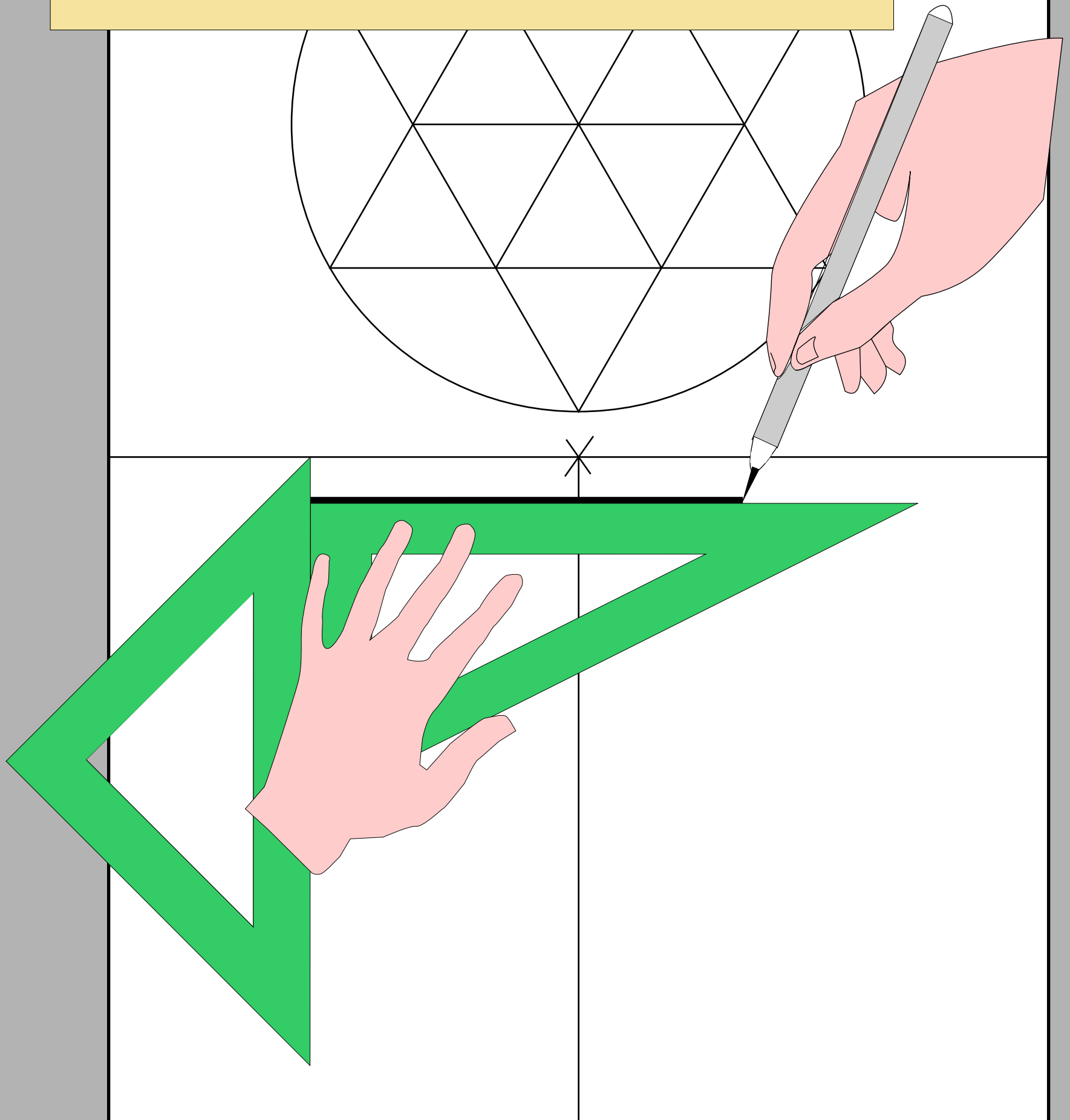

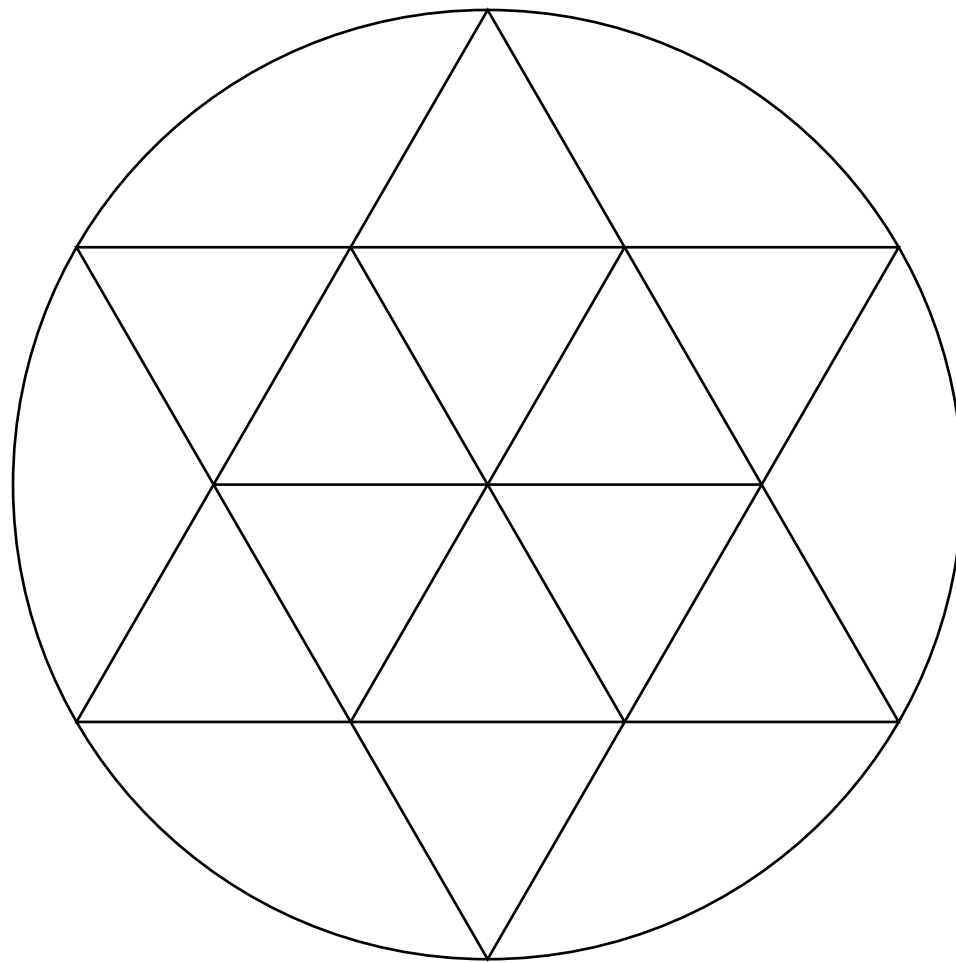

Prolongamos la horizontal de lado a lado.

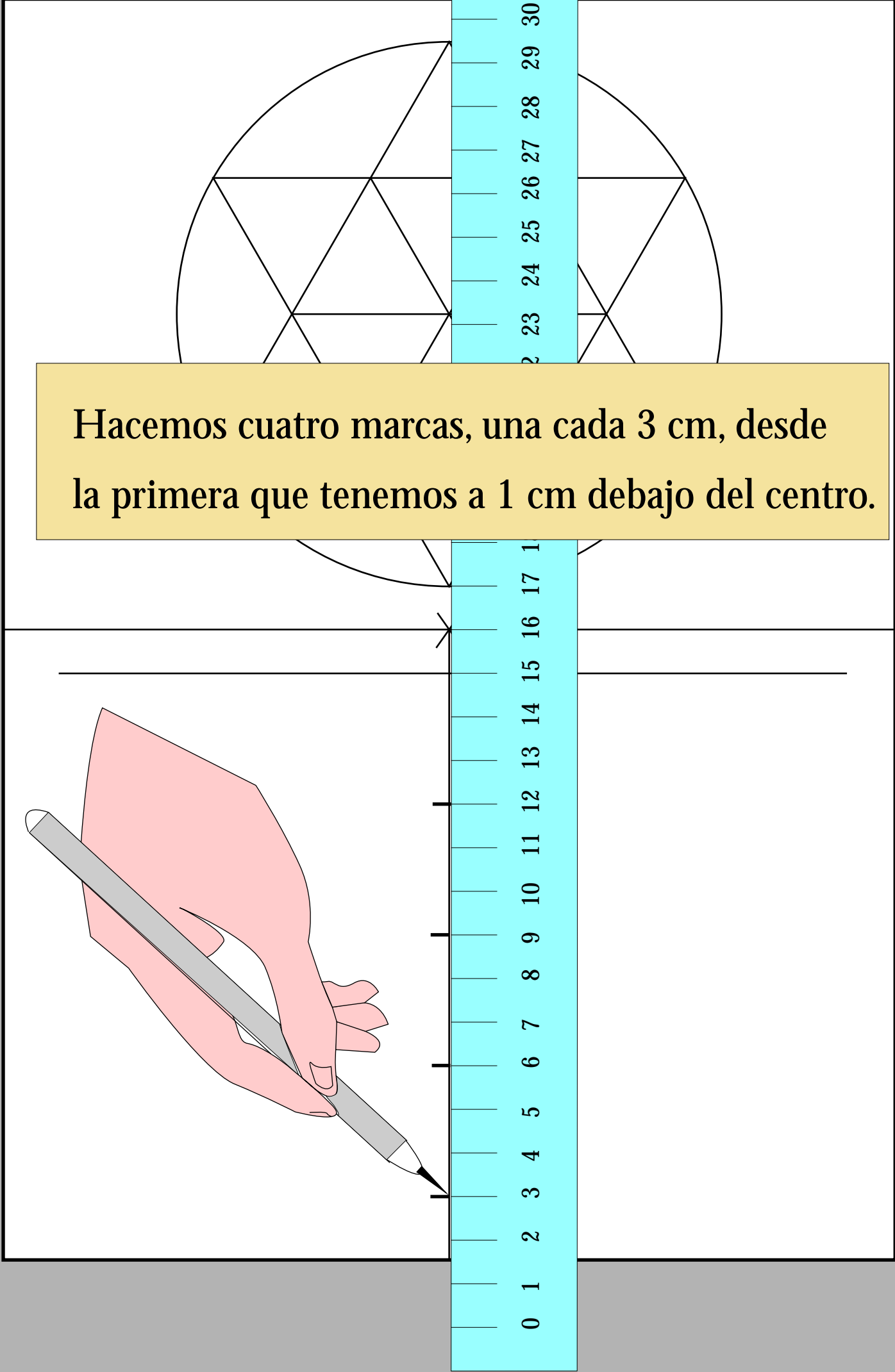

Hacemos cuatro marcas, una cada 3 cm, desde la primera que tenemos a 1 cm debajo del centro.

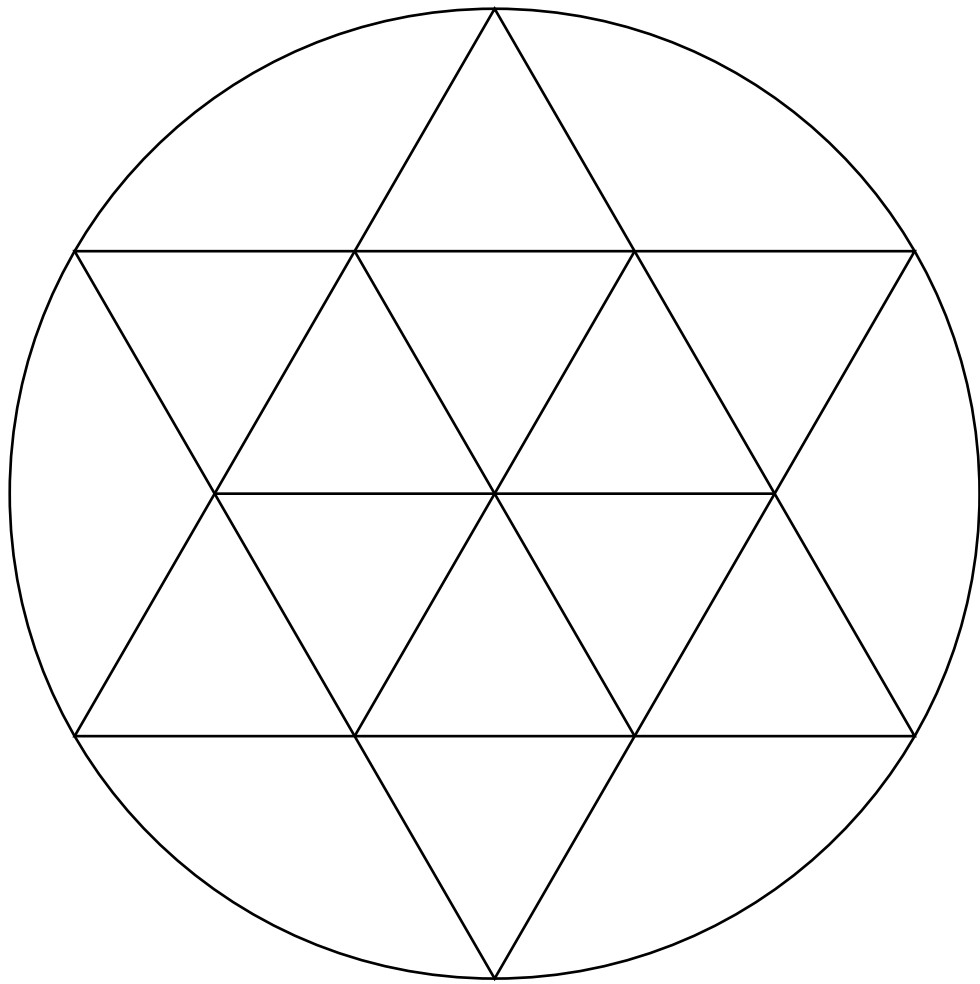

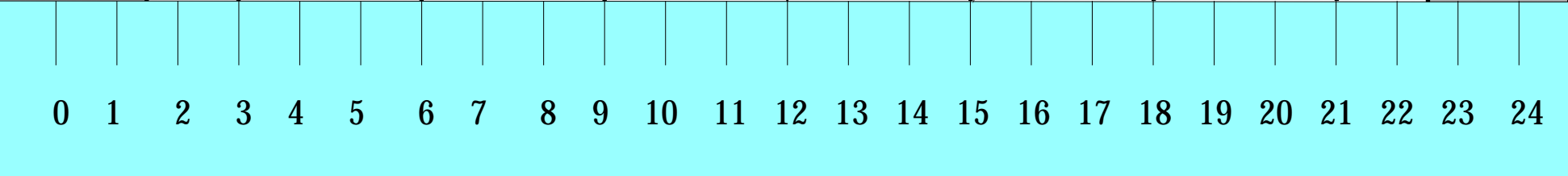
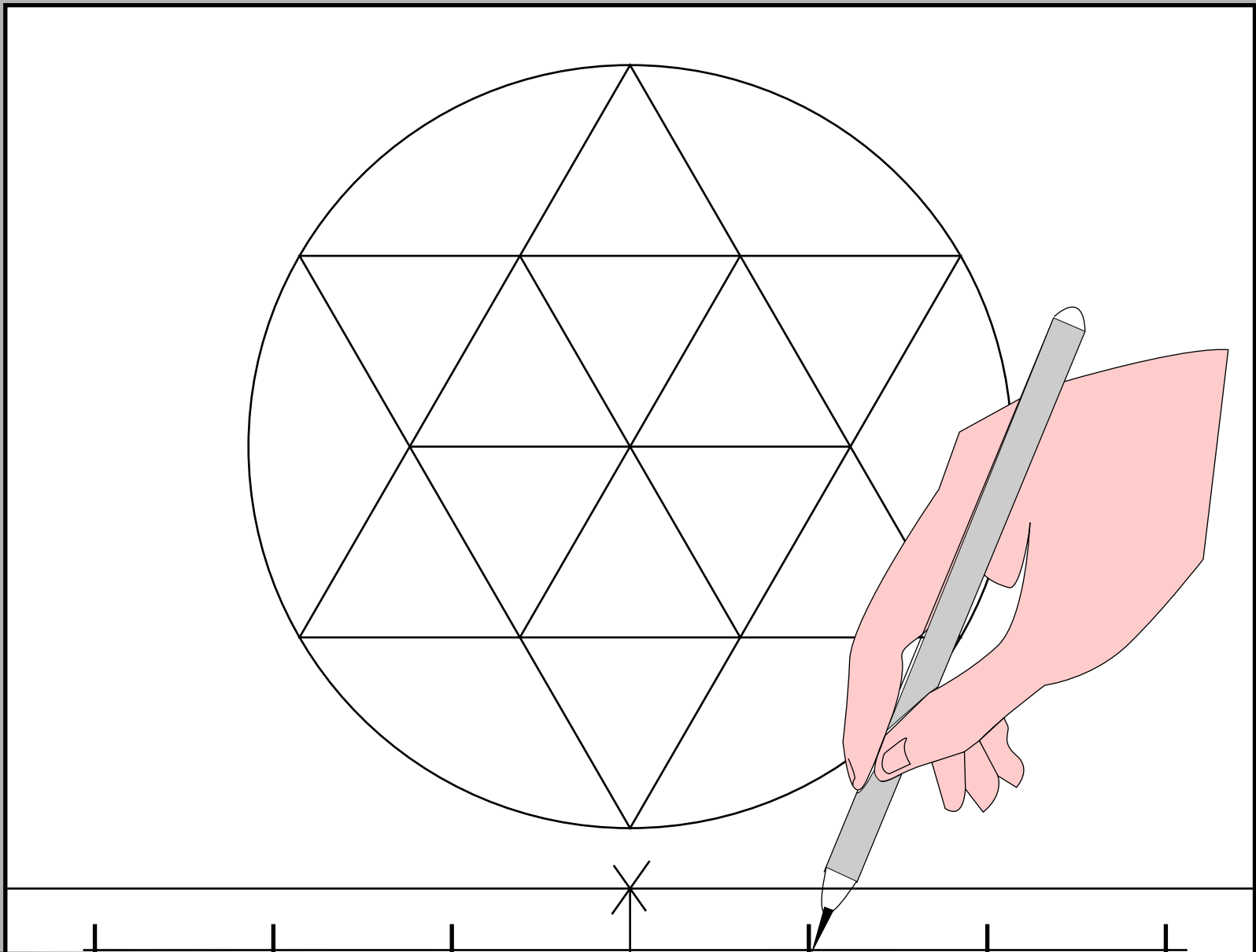

Hacemos tres marcas hacia cada lado del centro de la horizontal, cada 3 cm.

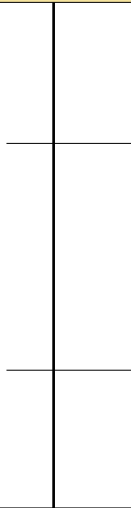

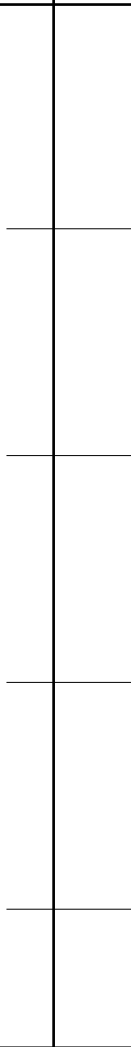
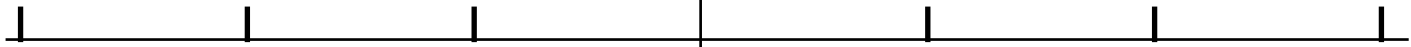
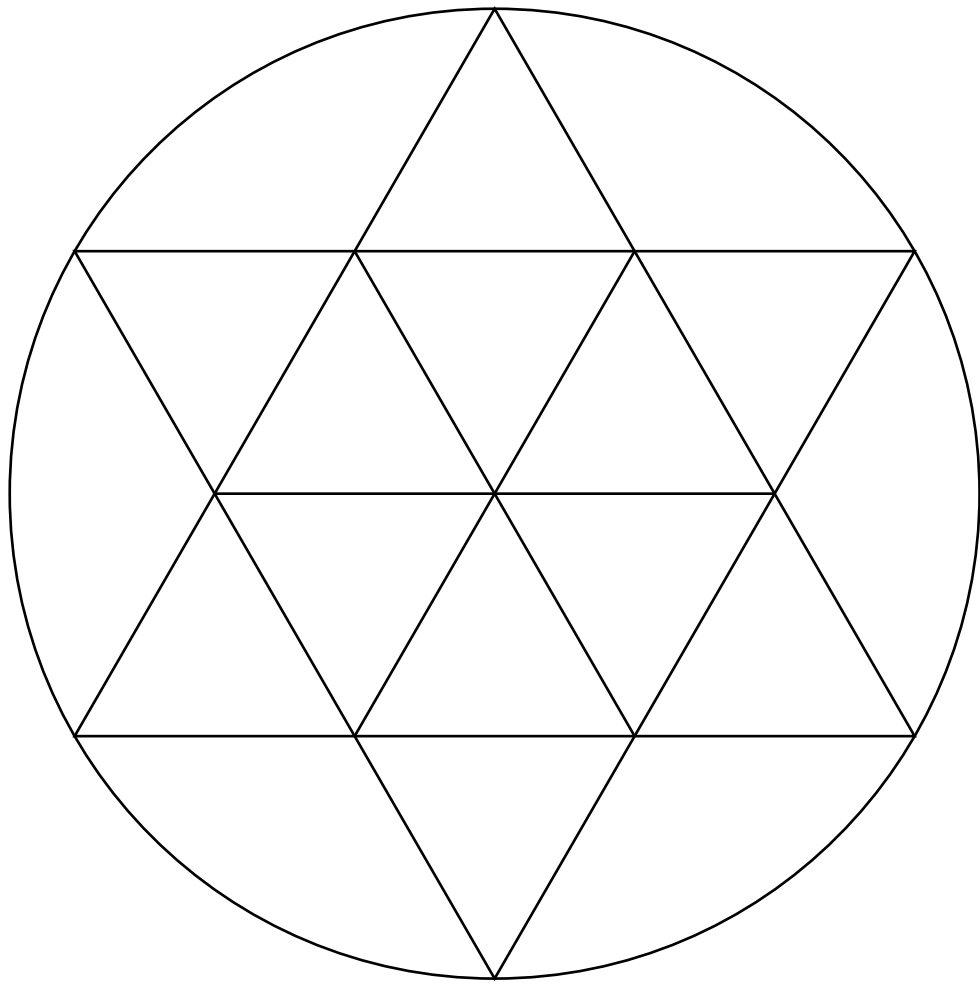

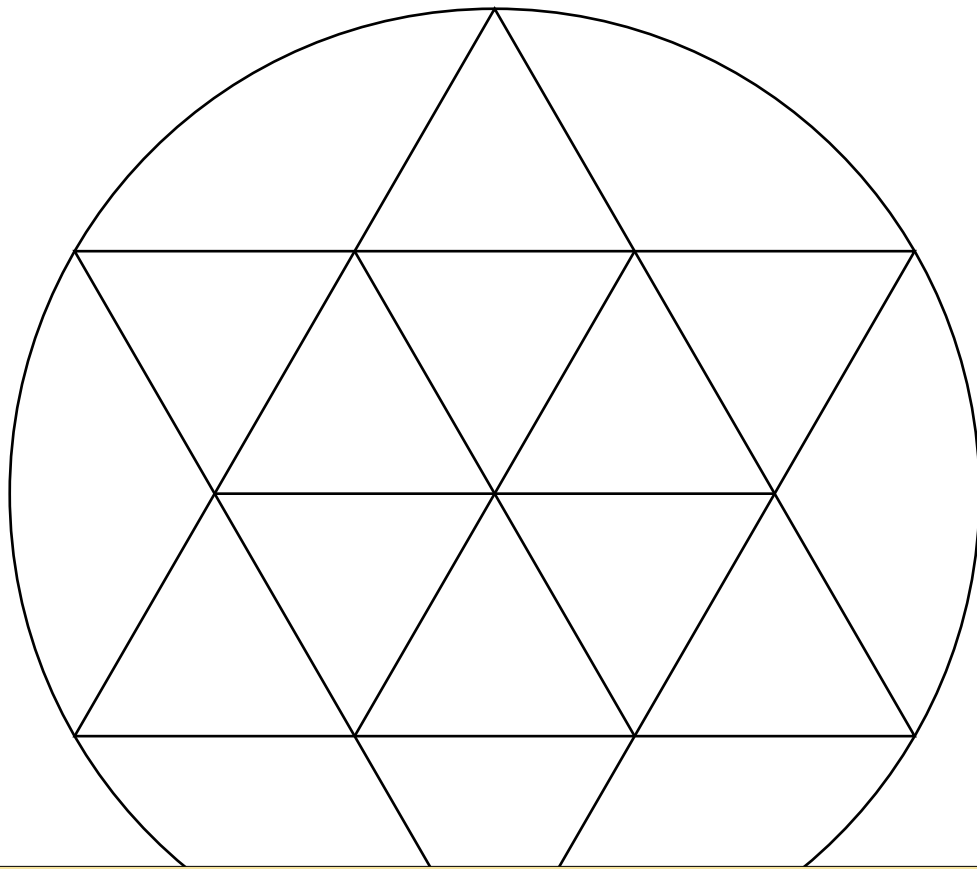

Alineamos el cartabón con la recta horizontal

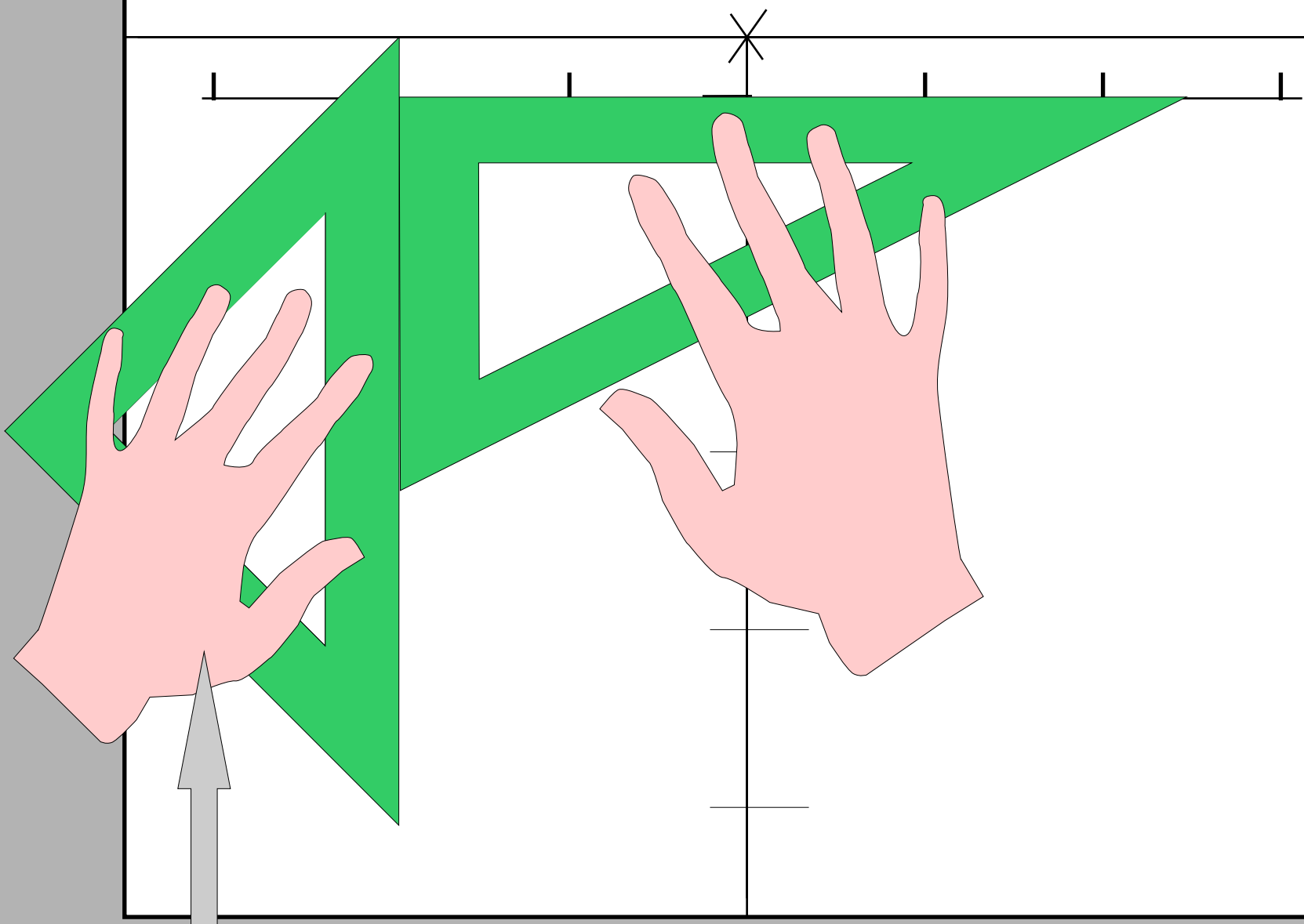

SUJETAR CON FUERZA

PILLANDO EL PAPEL

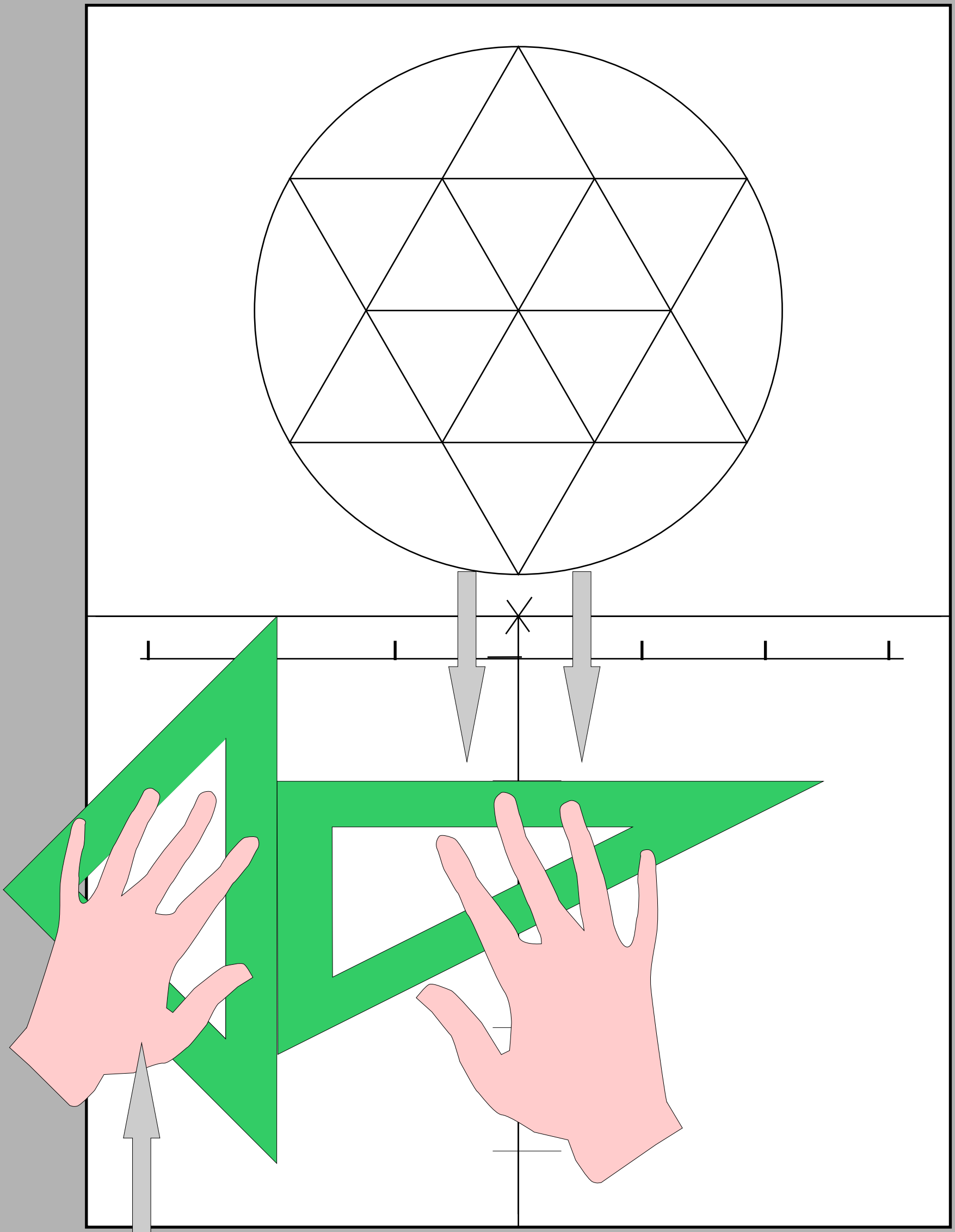

SUJETAR CON FUERZA

PILLANDO EL PAPEL

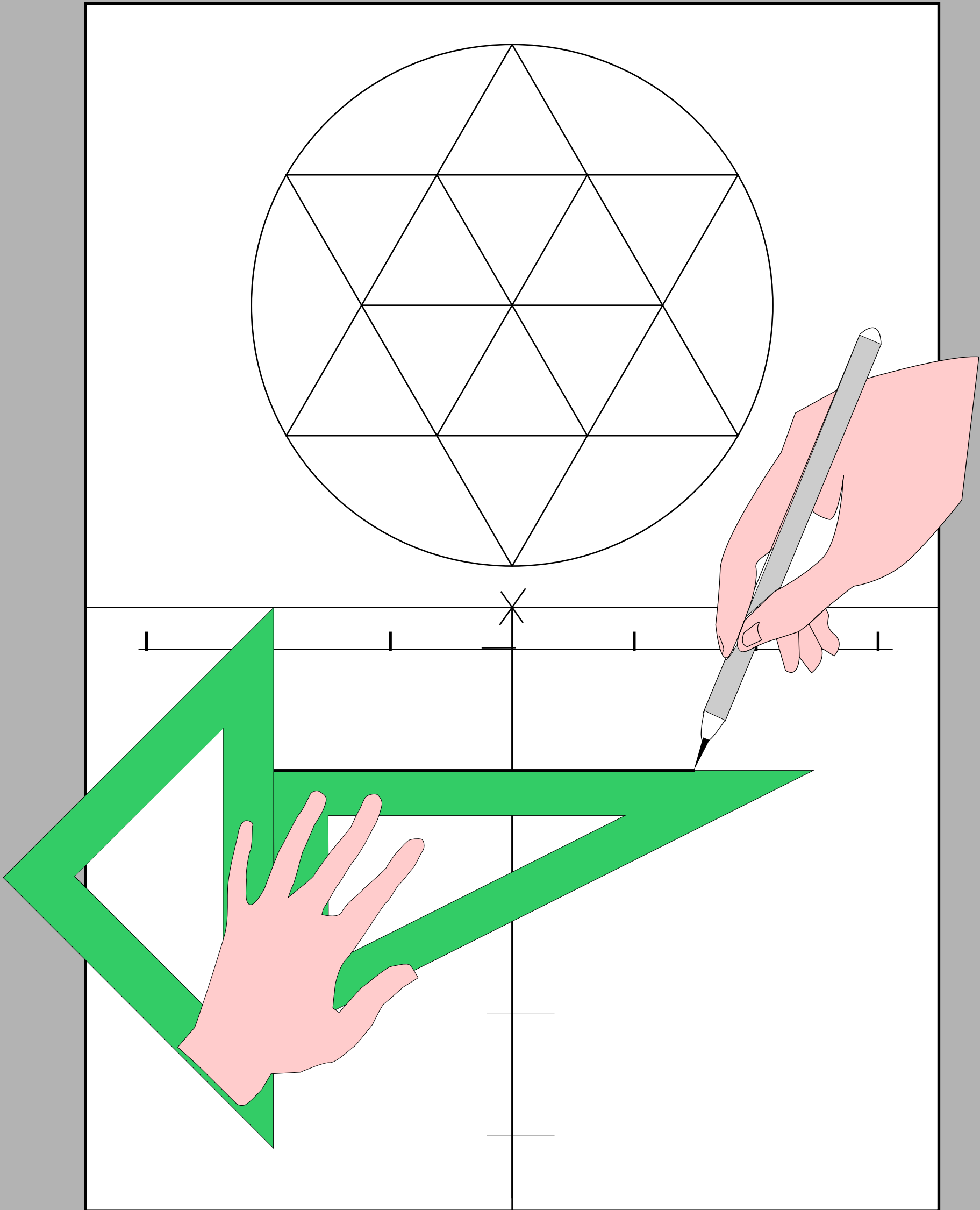

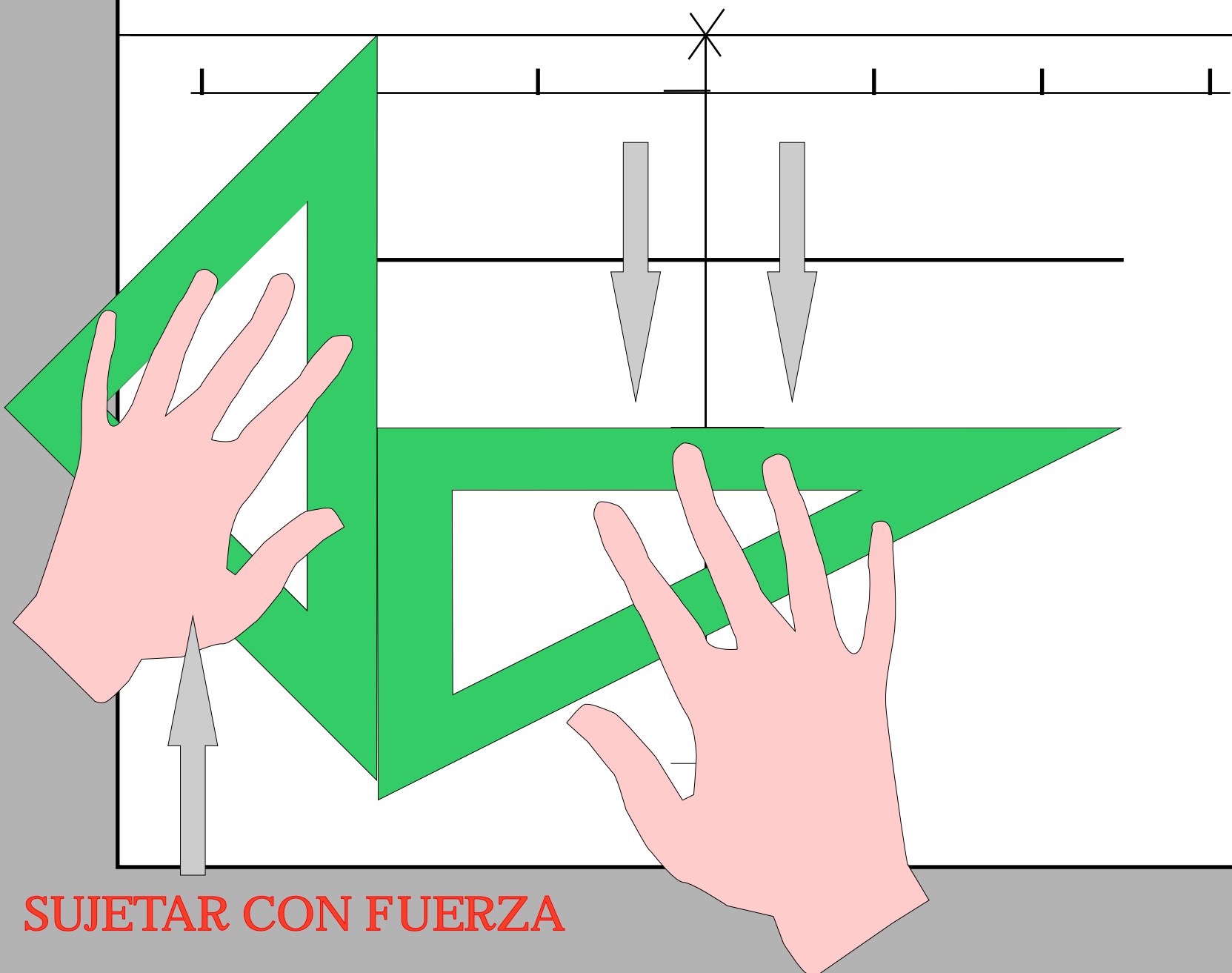
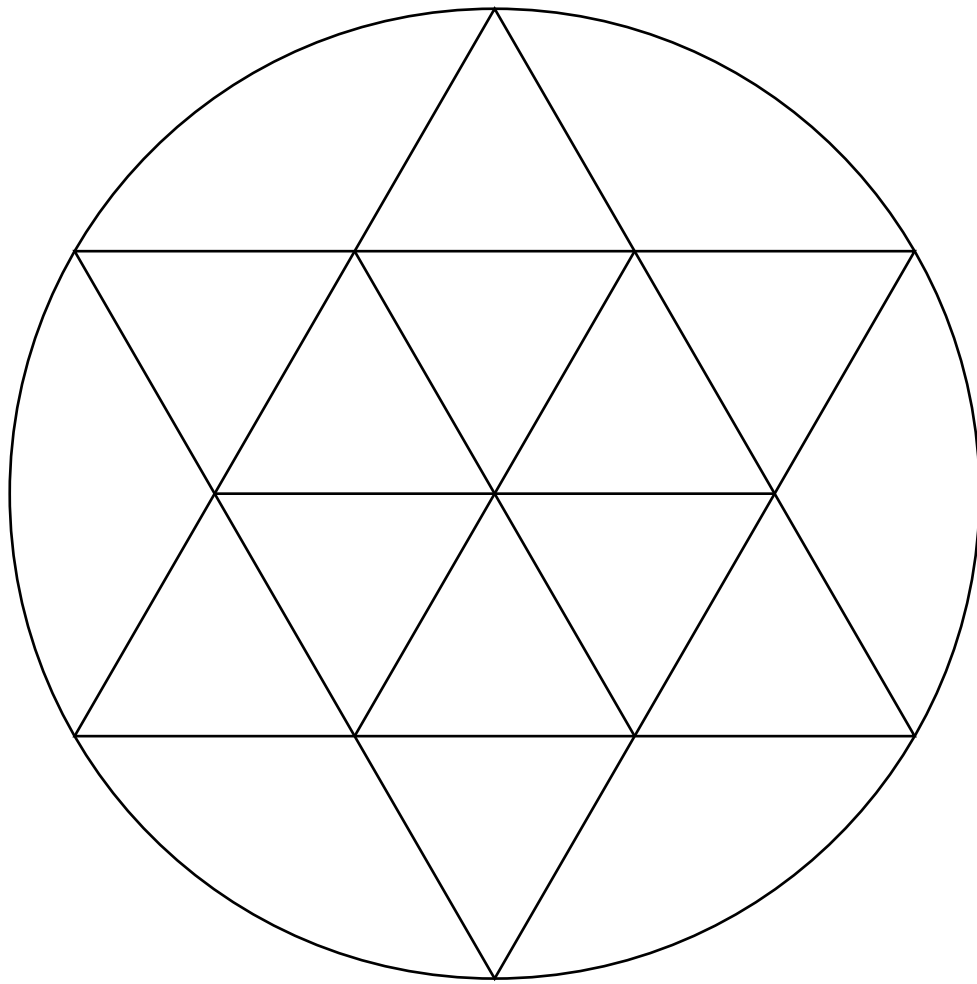

**SUJETAR CON FUERZA
PILLANDO EL PAPEL**

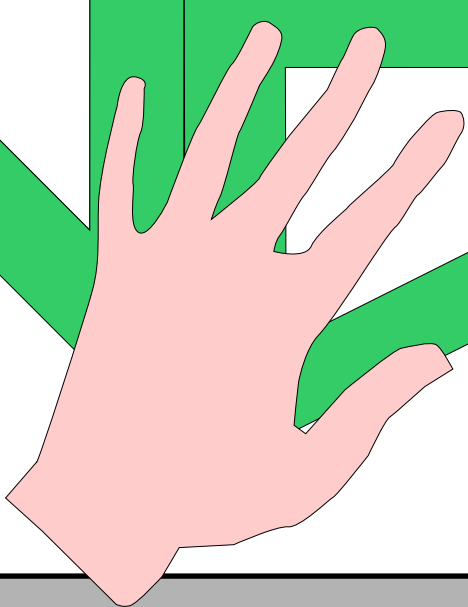
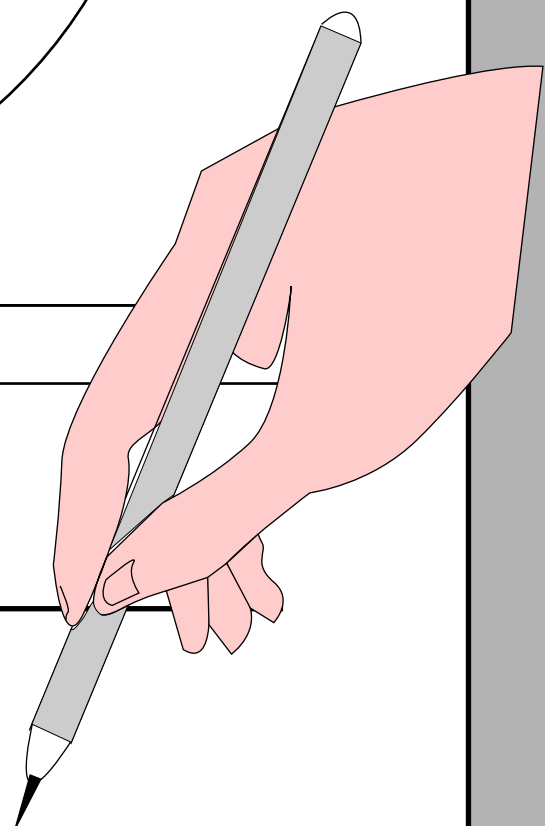
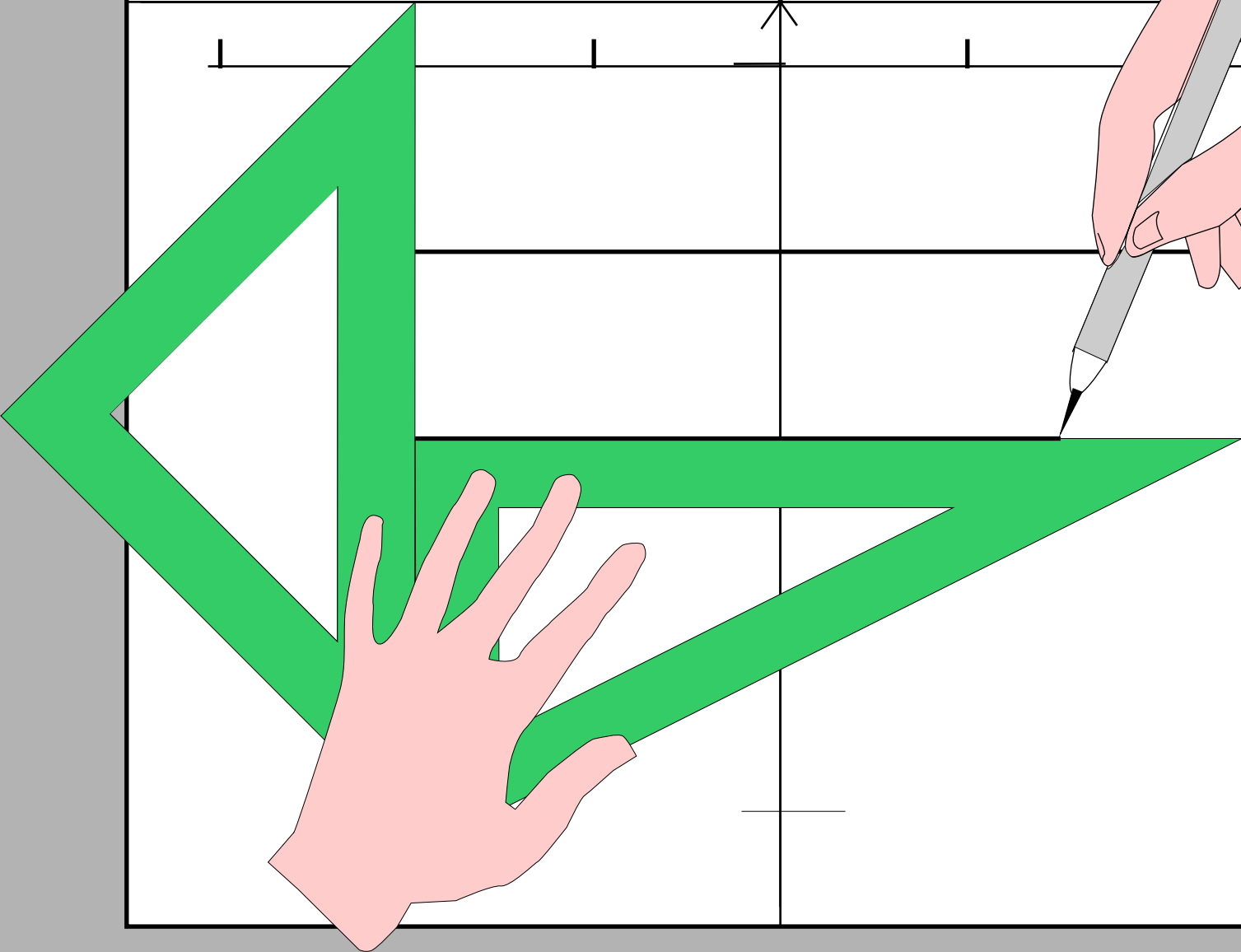
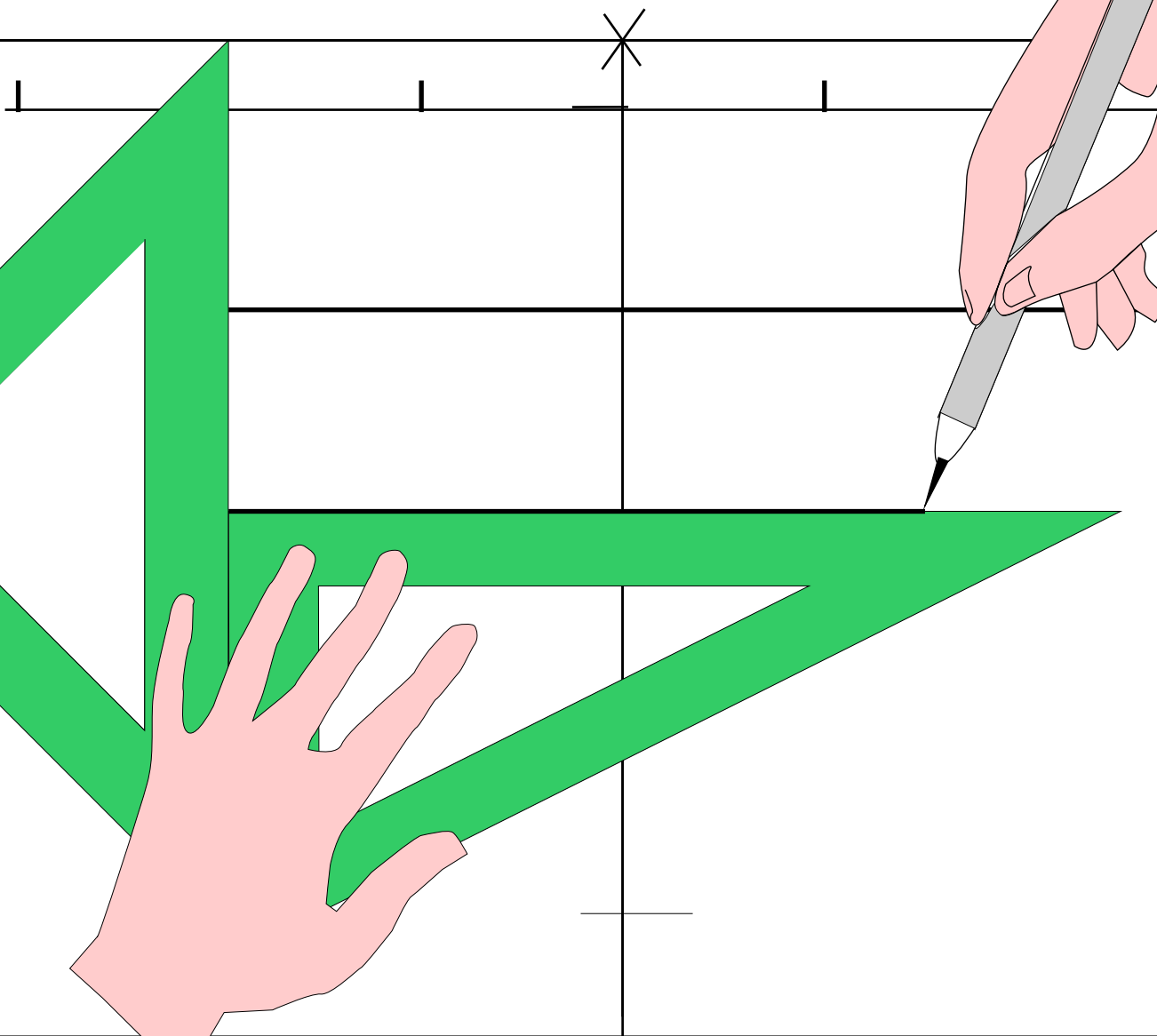
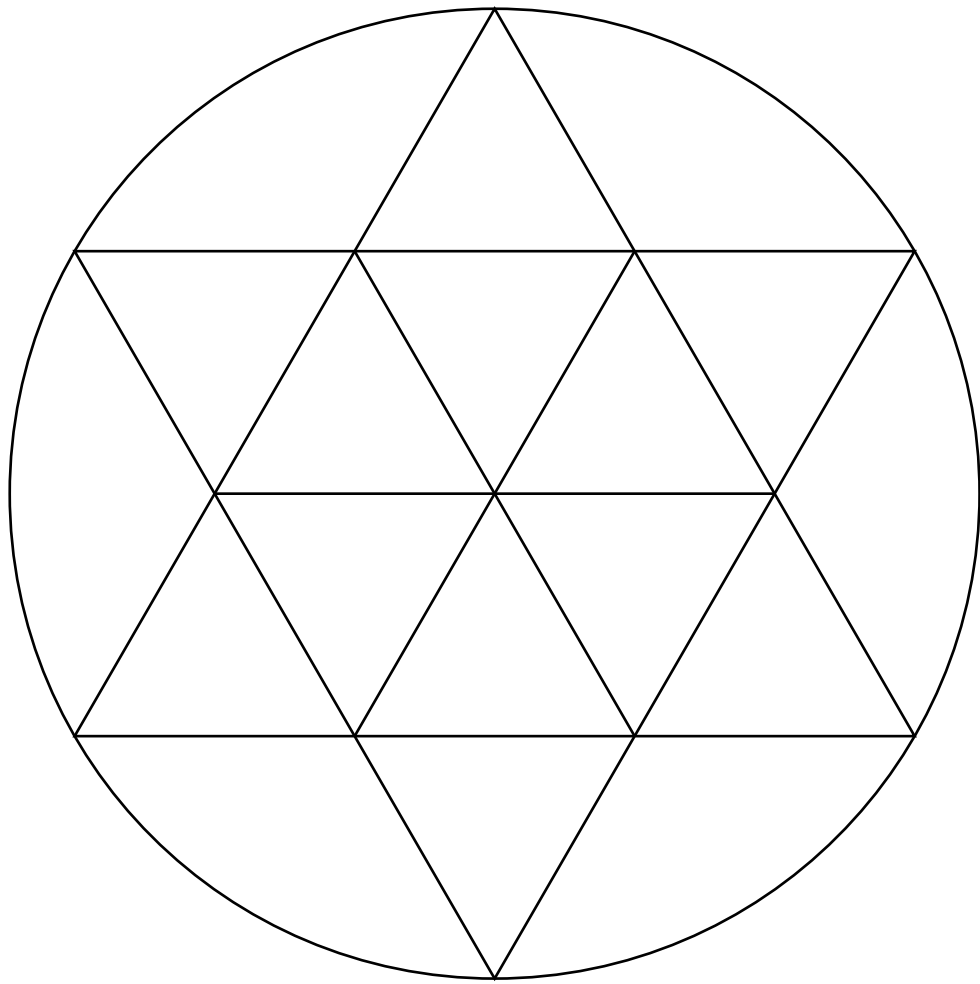

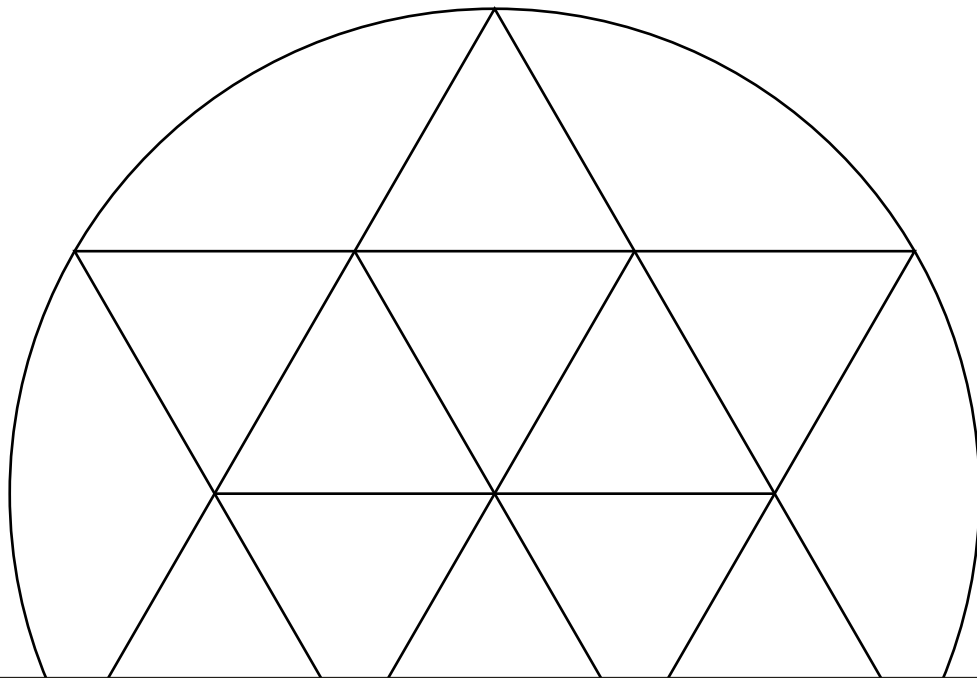

Completar de la misma forma las otras dos paralelas y prolongarlas con la regla.

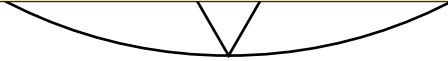

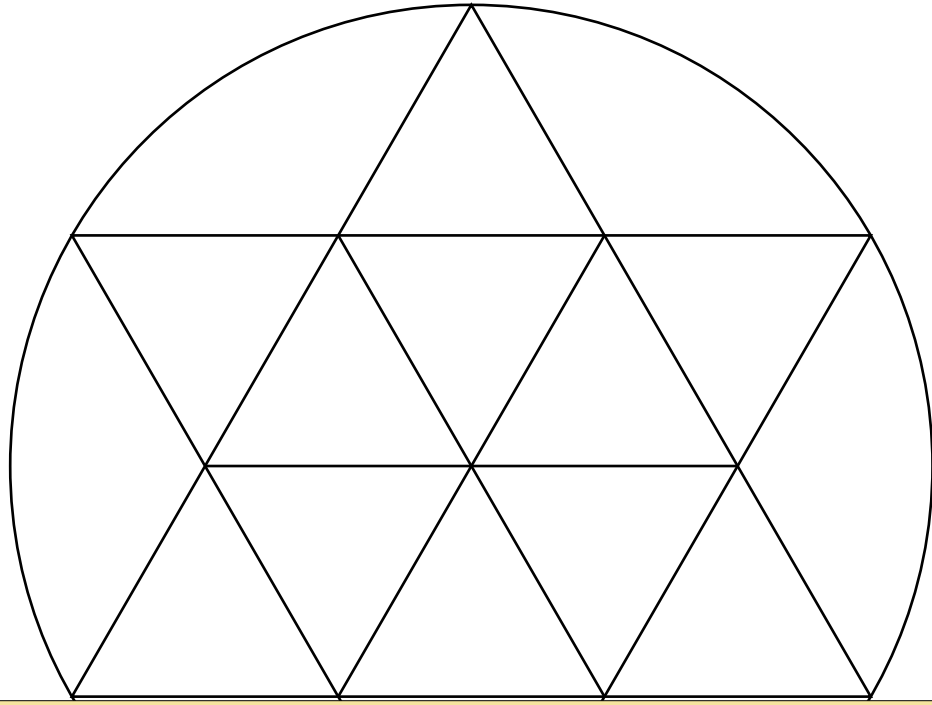

Alineamos el cartabón con la vertical que pasa por el centro.

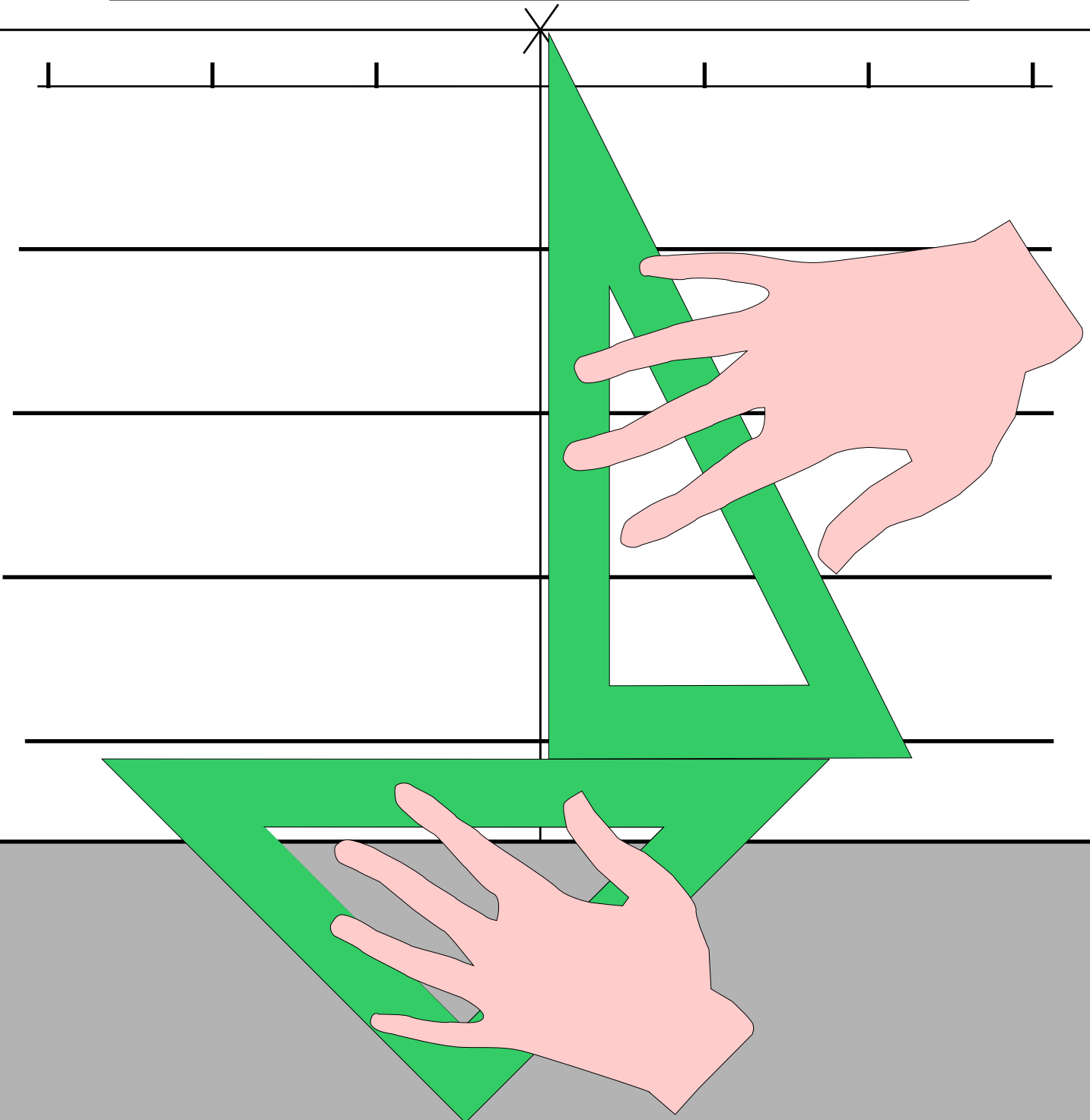

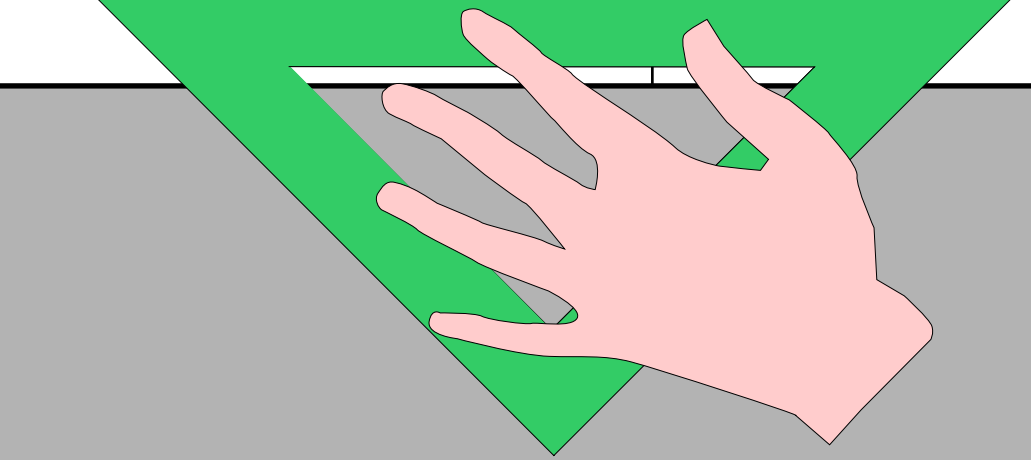
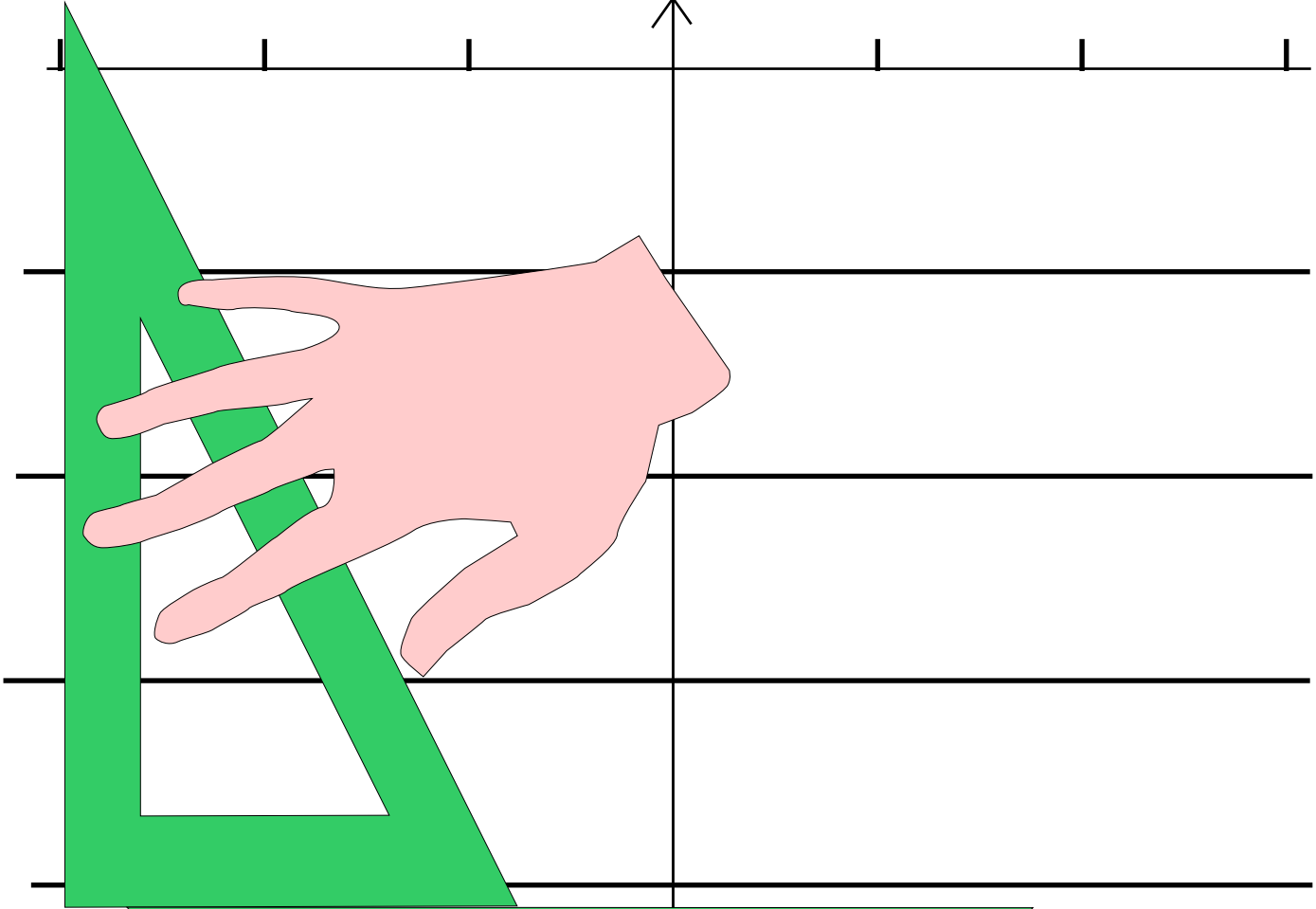
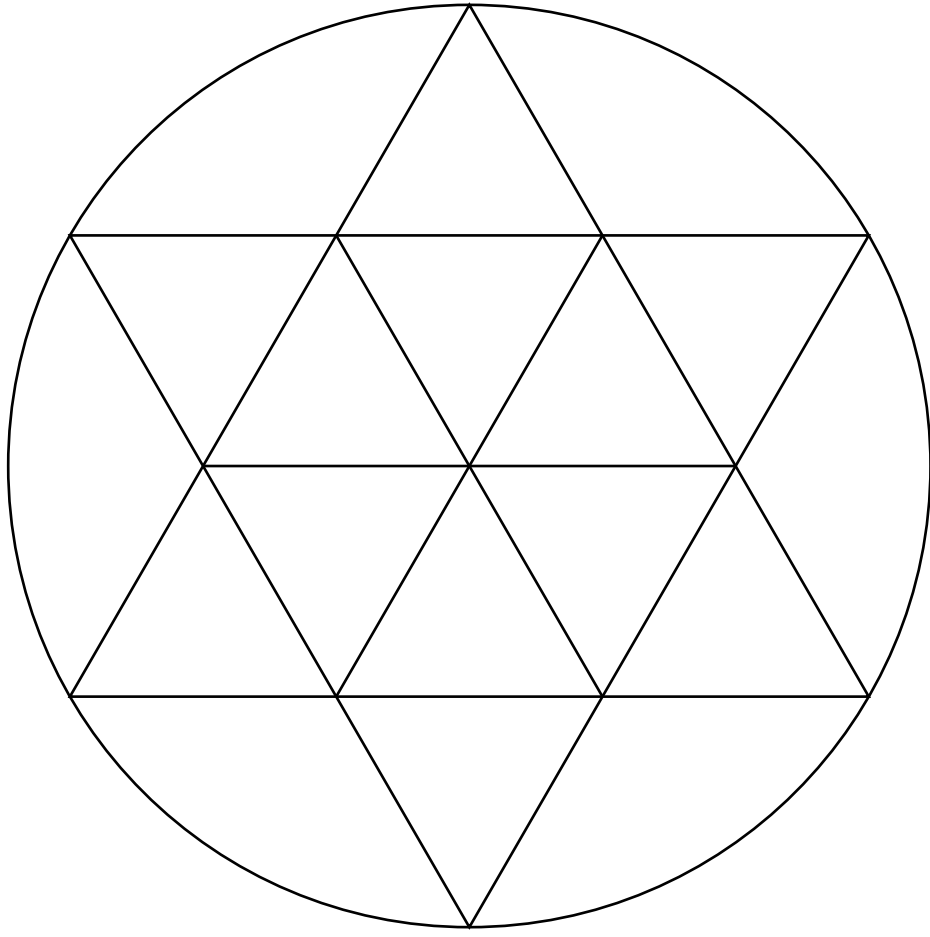

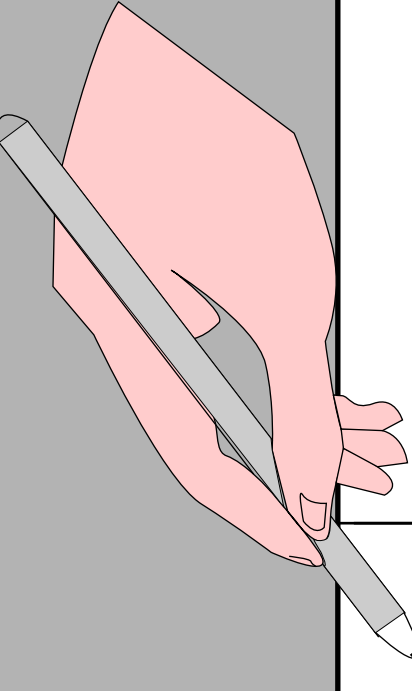
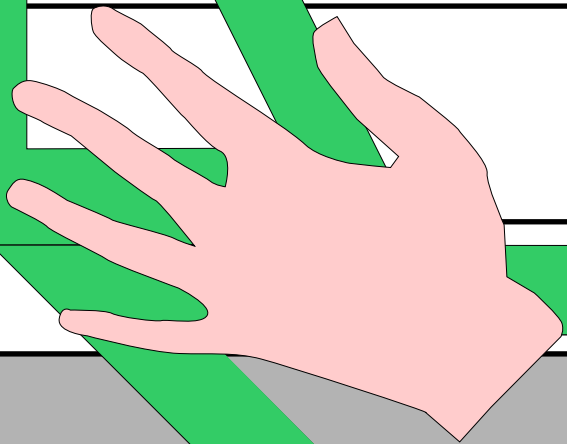
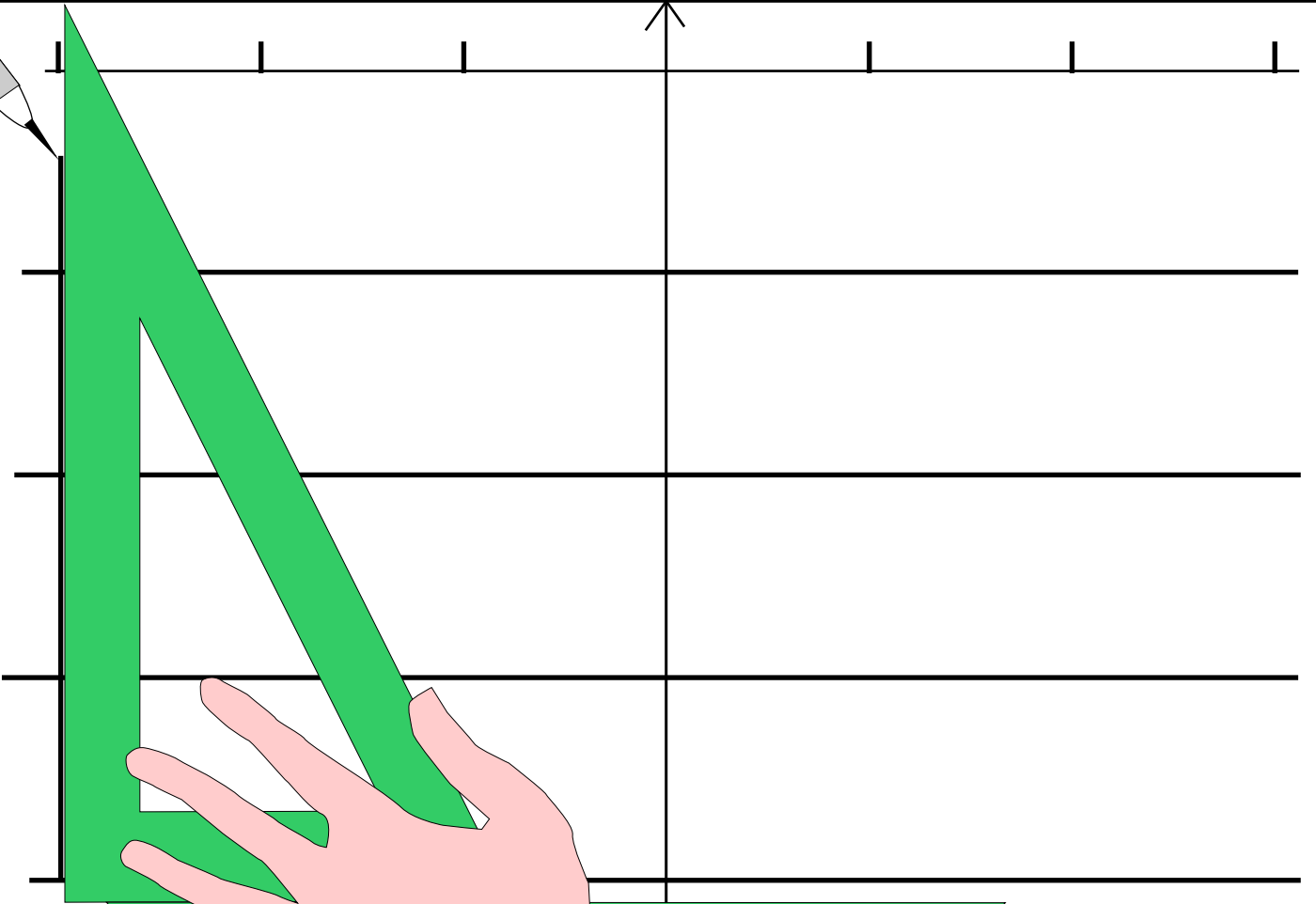
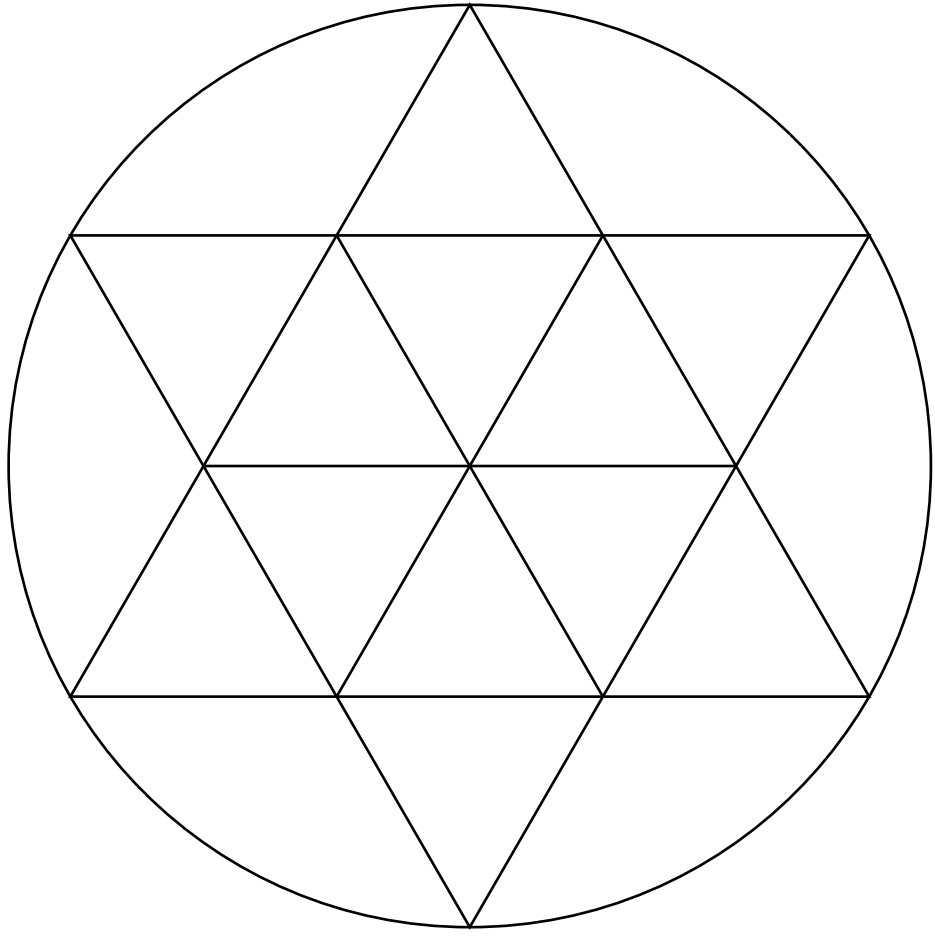

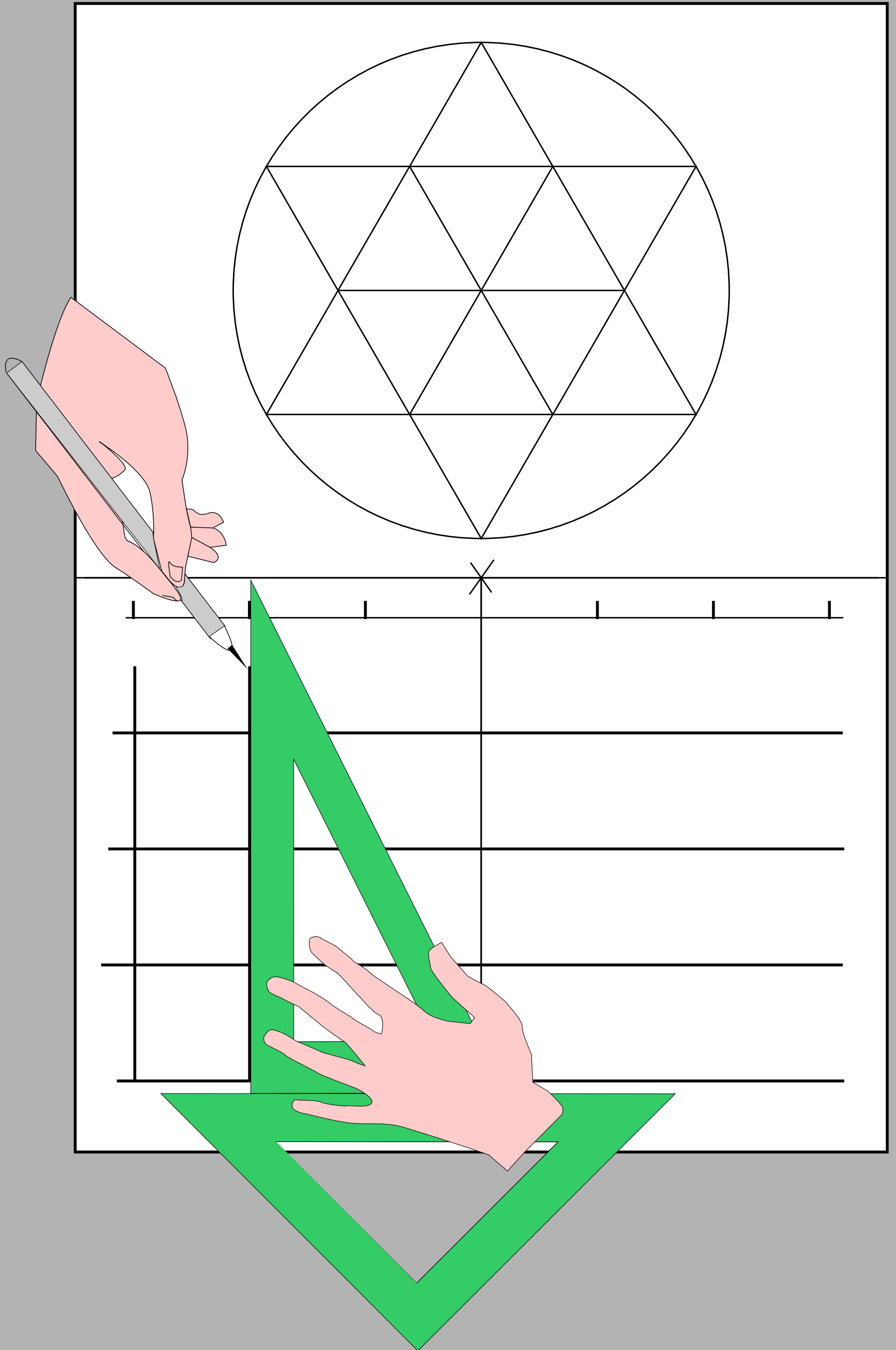

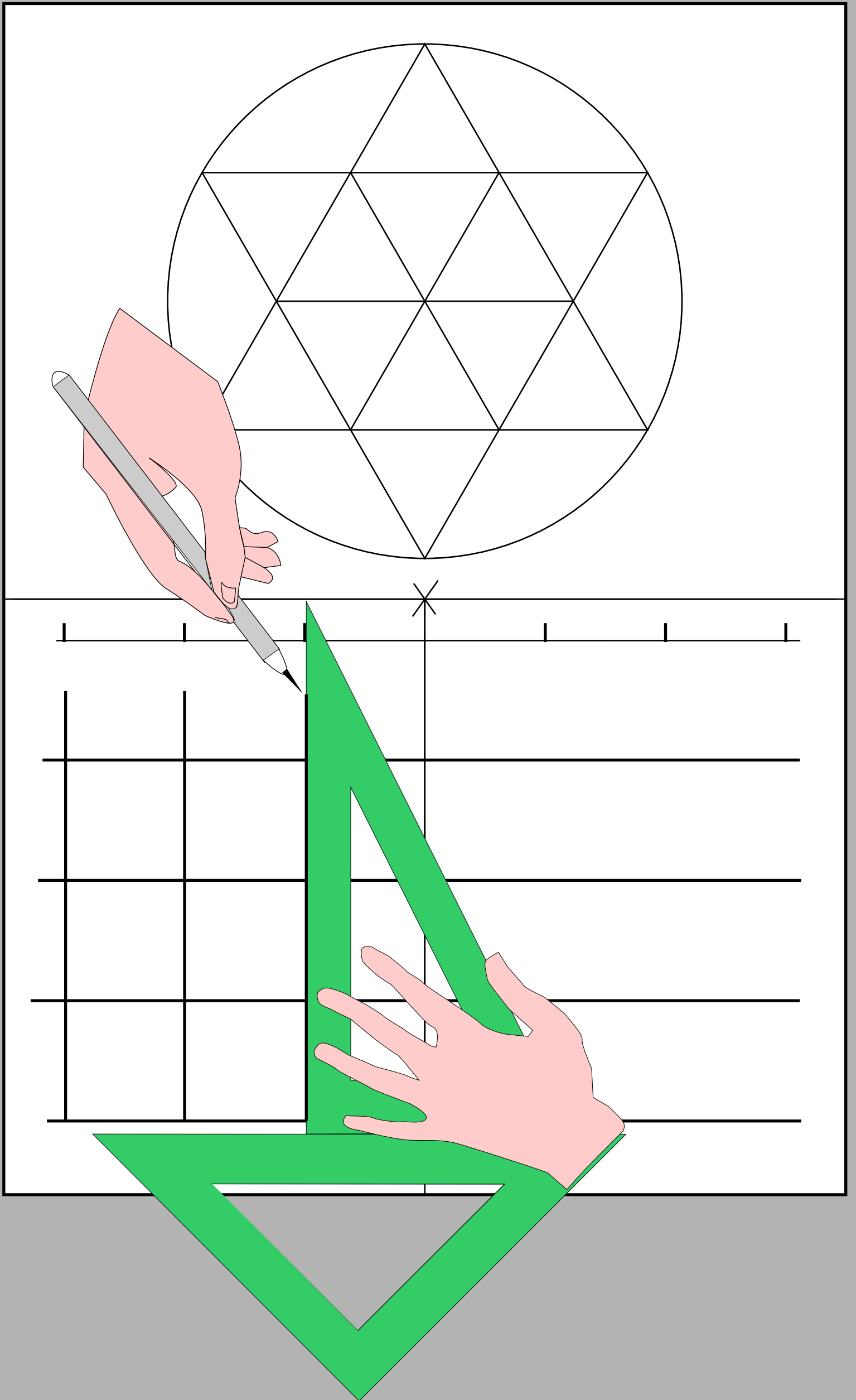

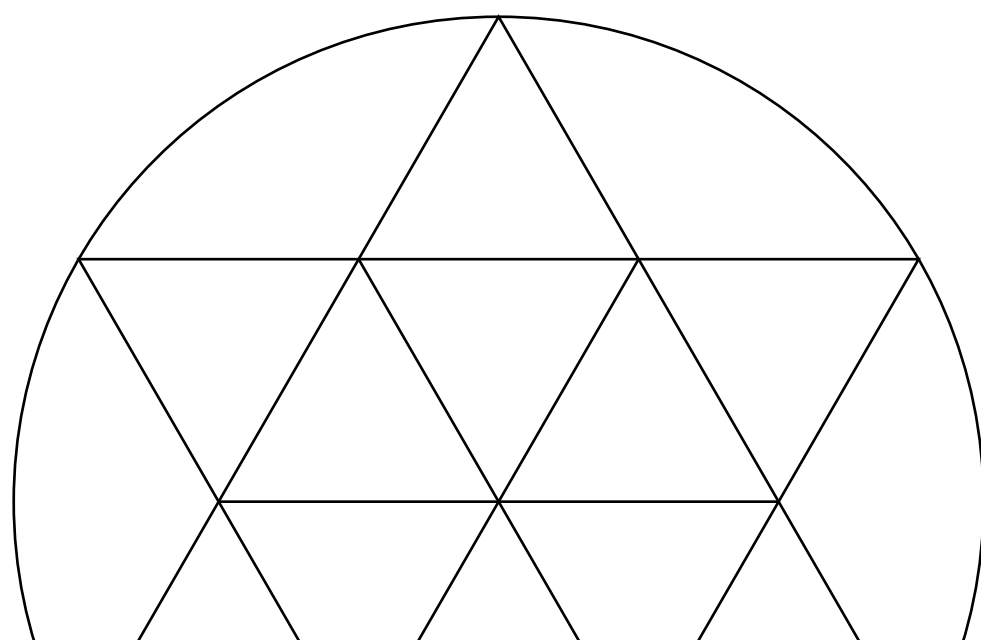

Dibujamos de la misma forma todas las paralelas completando una cuadrícula

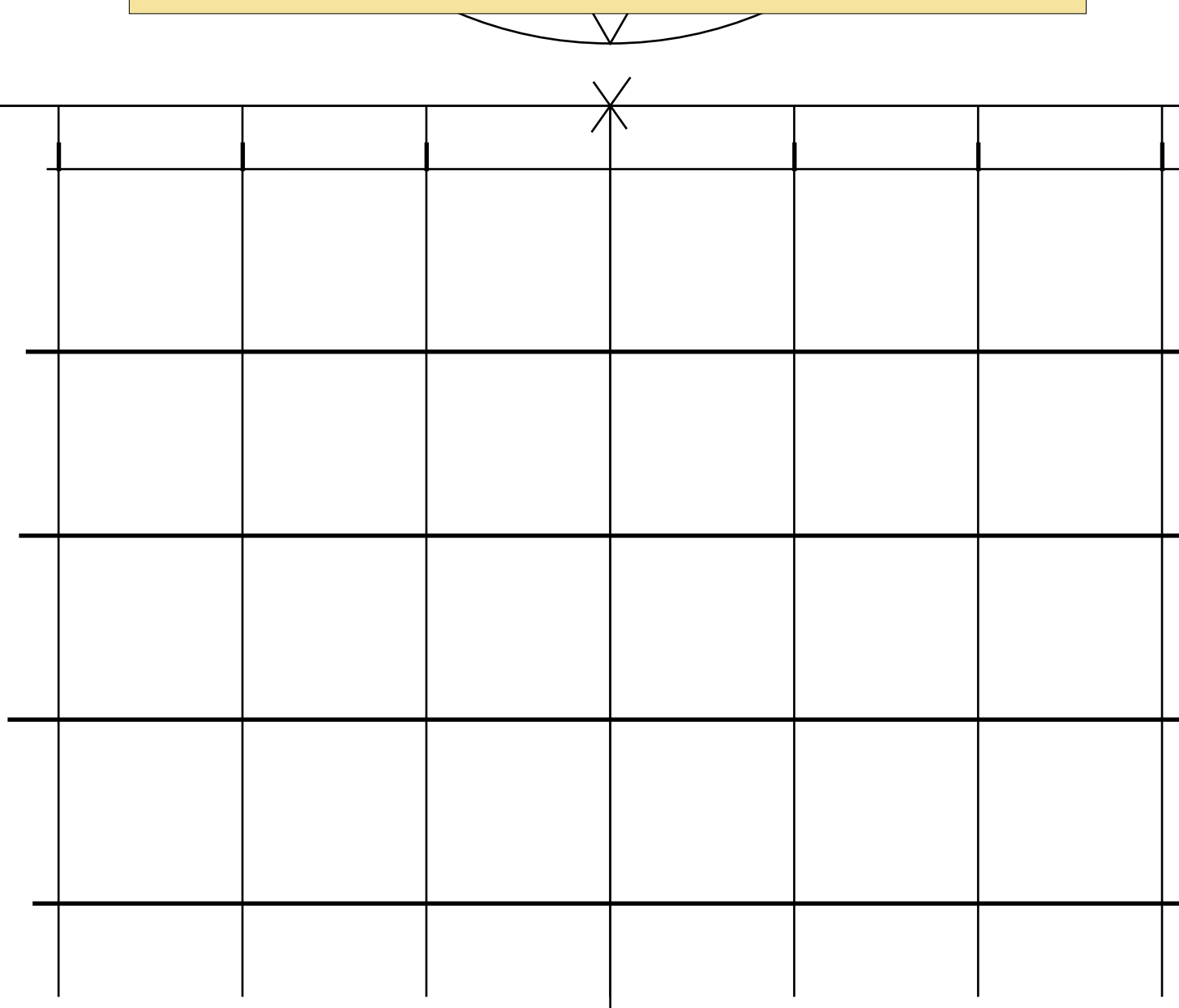

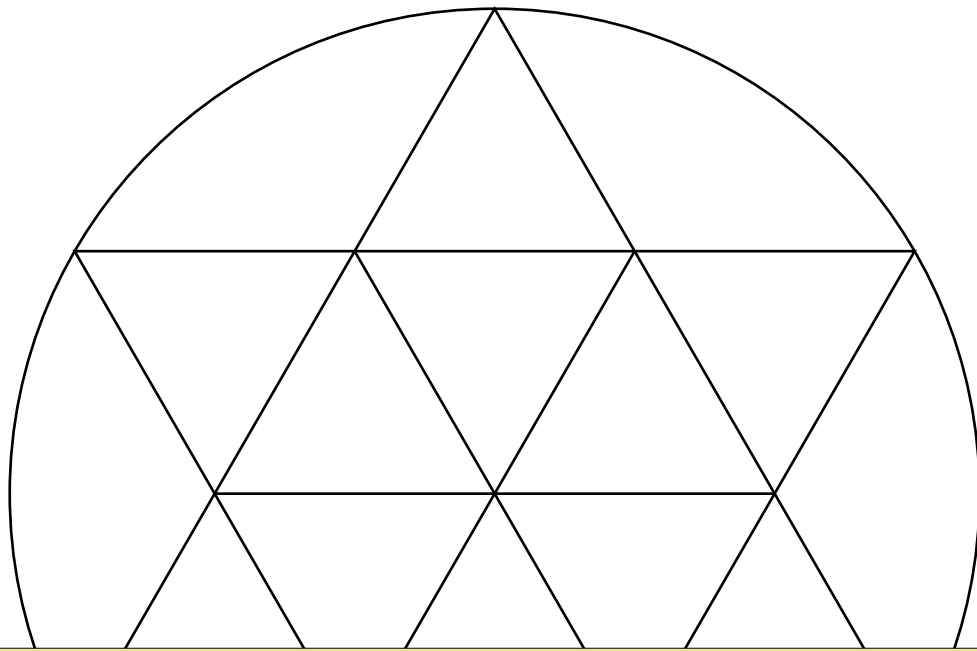

Borramos las partes de las rectas
que sobresalen



AMARILLO

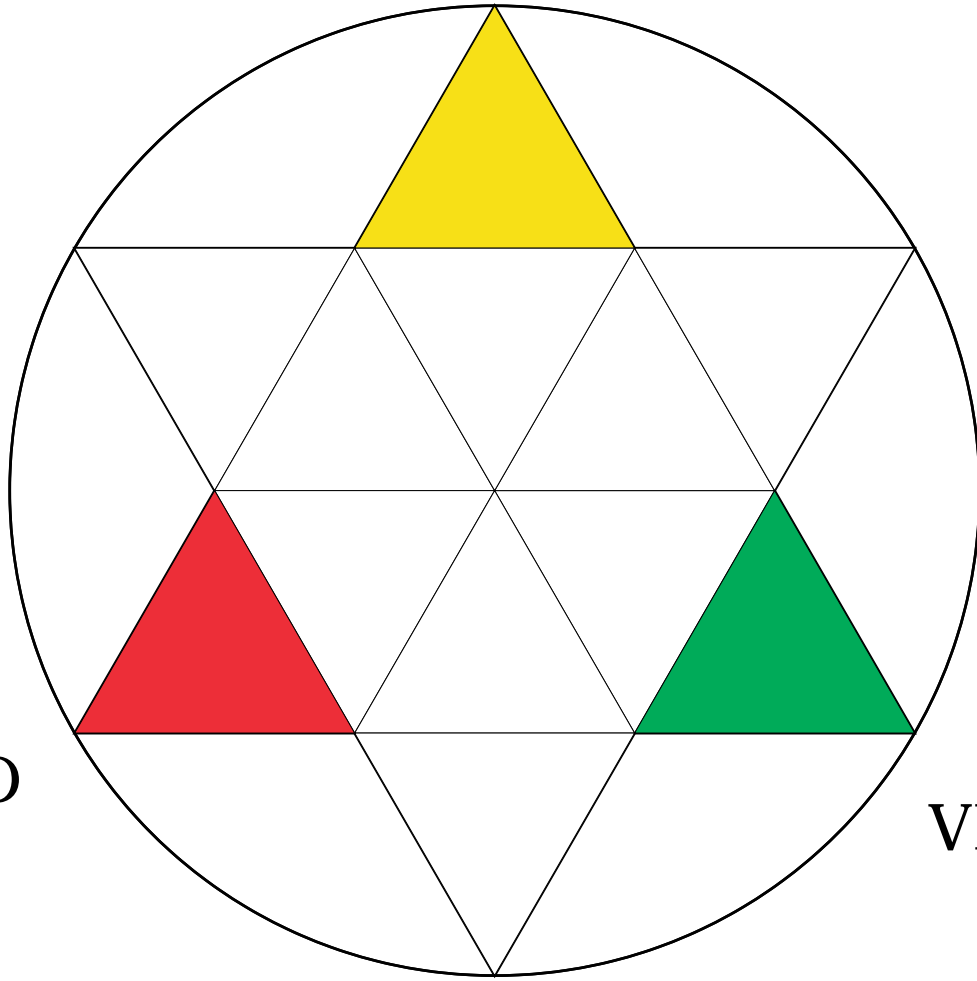

ROJO

VERDE



Pintamos con témperas estos triángulos

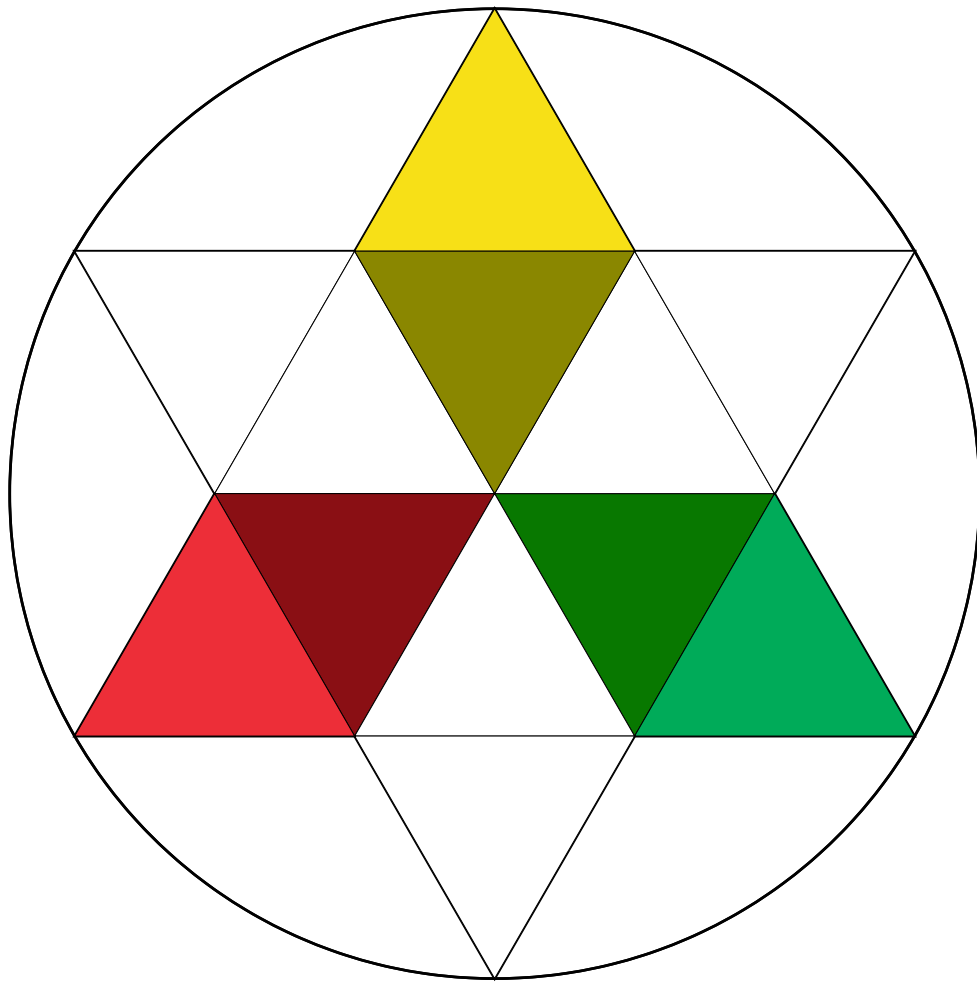

Añadiendo negro a cada color exterior

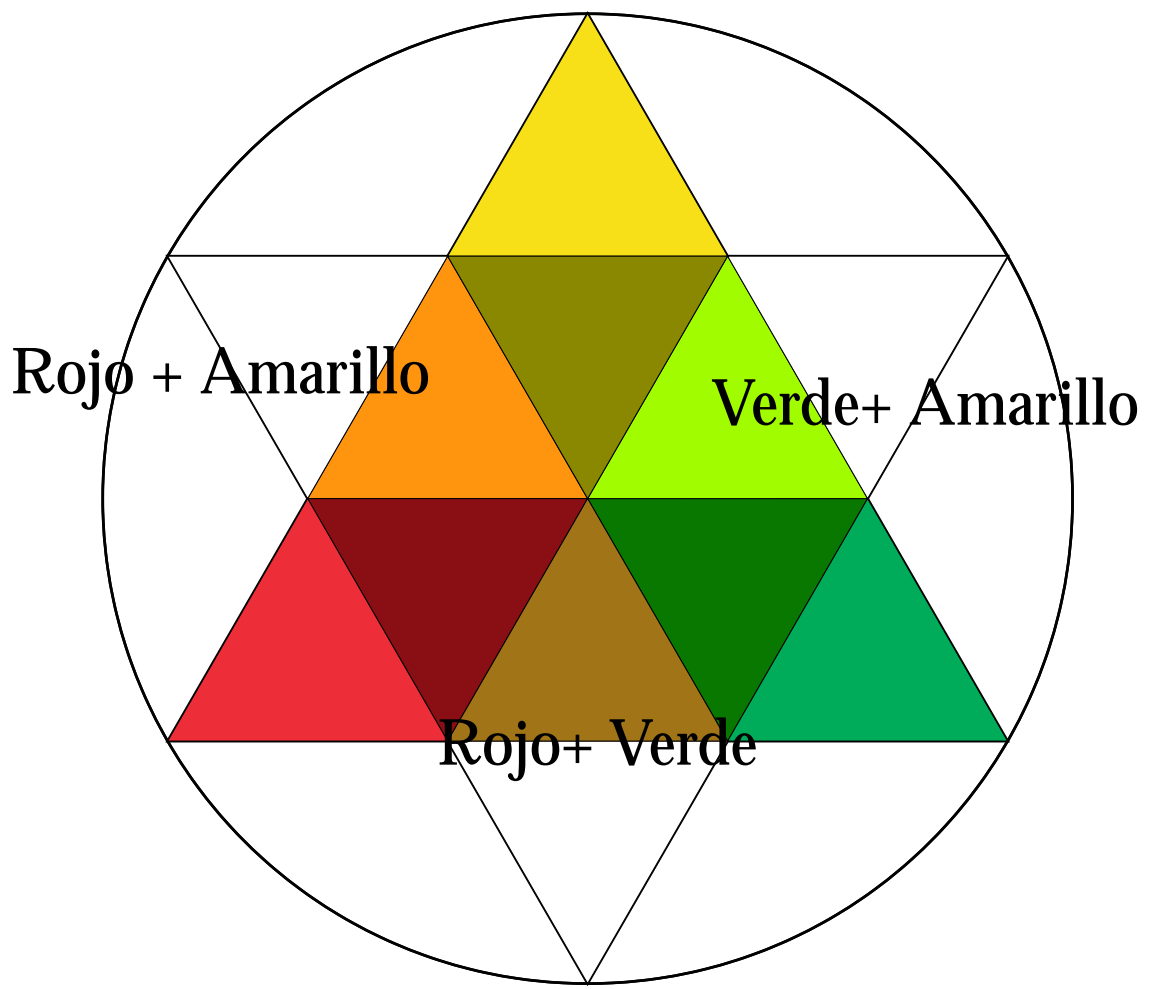

X

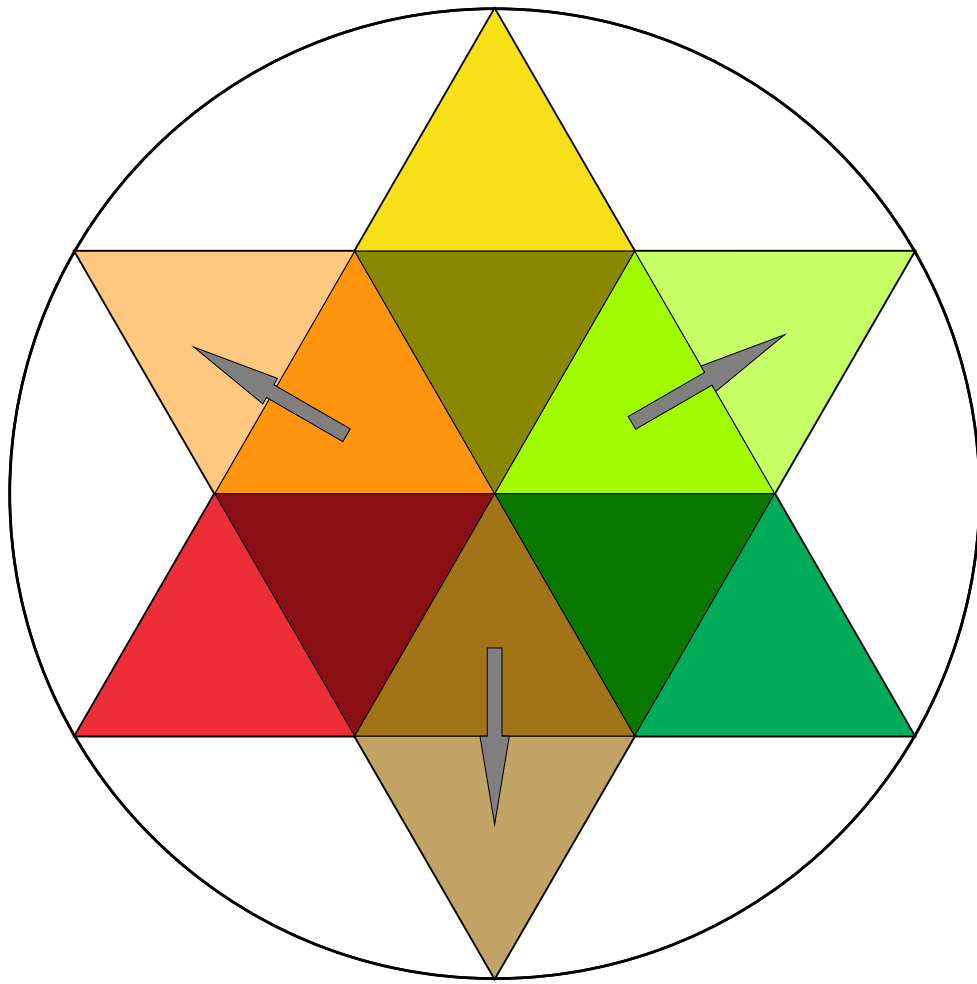

Añadiendo blanco a los colores que acabamos de conseguir, según las direcciones de las flechas.

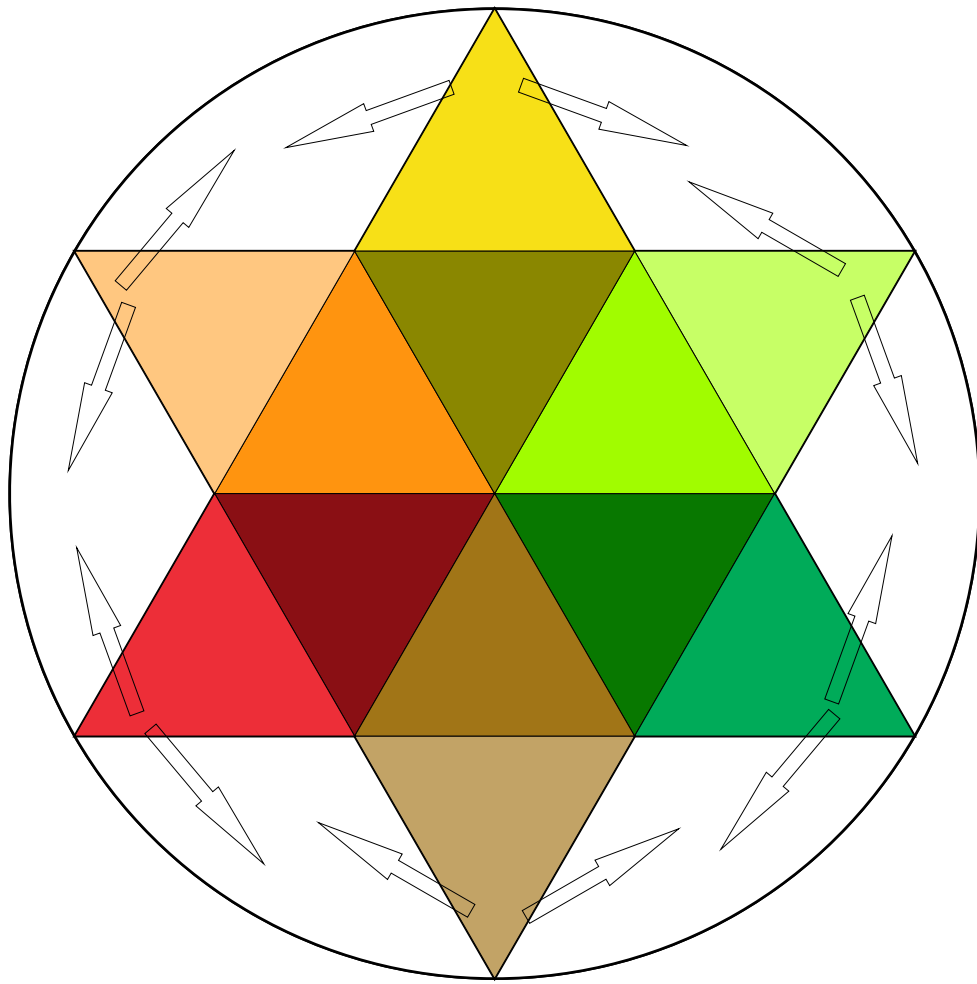

Estos últimos colores los mezclamos con los que tienen a sus lados: con el amarillo, con el verde y con el rojo, según las flechas, rellenando las partes del círculo que nos quedan.

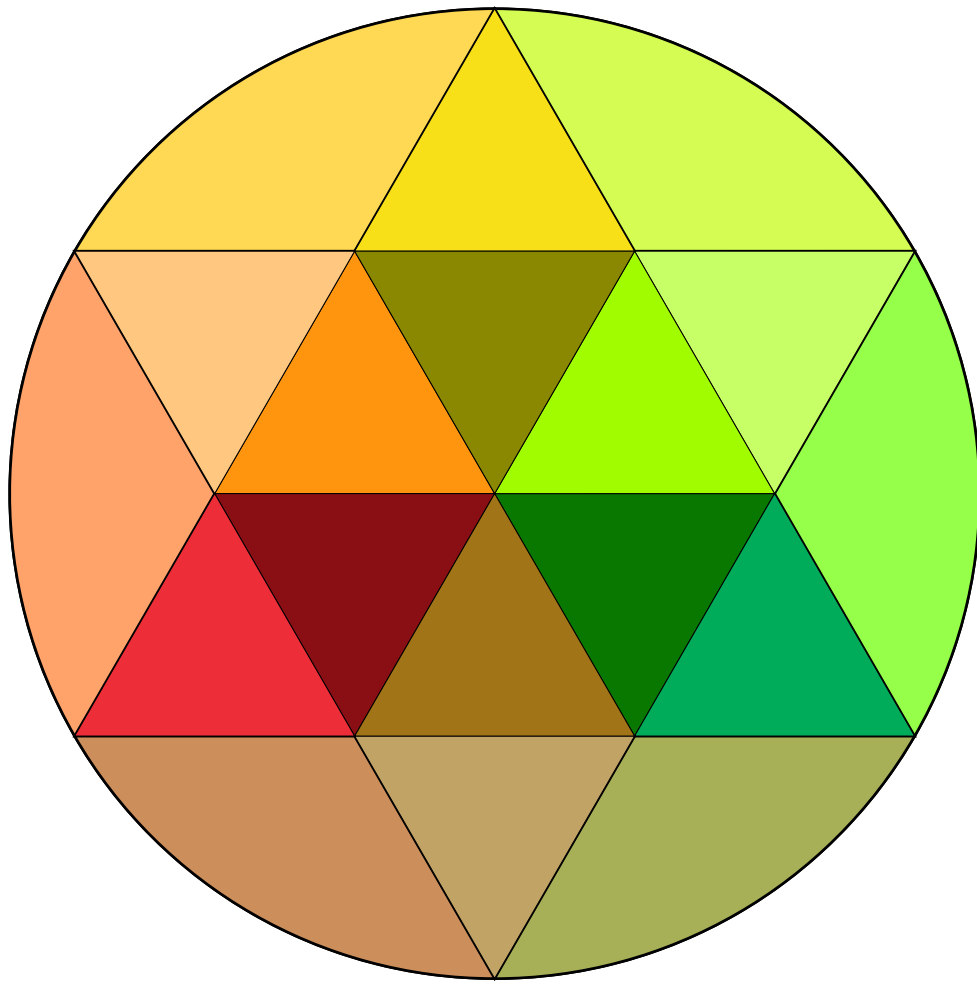

X



En los cuadrados de abajo, se hace lo siguiente:

En uno se pega un recorte cuadrado de 3X3cm que sacaremos de una revista, buscando fragmentos de colores cálidos en cualquier fotografía; y en el cuadrado siguiente intentaremos conseguir el mismo color mediante mezclas similares a las que hemos hecho en la estrella de arriba, aunque podemos variar las cantidades de color que añadimos, puesto que hay muchos matices que no aparecen en la misma.

