

DO NOT PRINT THIS PAGE
DO NOT PRINT THIS PAGE

On an A4 drawing paper, we will draw the usual margin and boxes. Here you can see the lengths to use, expressed in millimetres.

20

10

10

DO NOT PRINT THIS PAGE
DO NOT PRINT THIS PAGE

DO NOT PRINT THIS PAGE
DO NOT PRINT THIS PAGE

DO NOT PRINT THIS PAGE
DO NOT PRINT THIS PAGE

DO NOT PRINT THIS PAGE
DO NOT PRINT THIS PAGE

DO NOT PRINT THIS PAGE
DO NOT PRINT THIS PAGE

10

10

10

40

A

Now, we are going to divide the segment AB into three equal parts, by using the Thales Theorem.



Draw a ray from the point A, then take three equal segments on it, using your compass. It doesn't matter the length or the angle of the ray, nor does the length of the segments, as long as they are equal.

B

A

Now, we connect the points 3 and B.



B



And, using our set squares, we draw two parallel lines to the previous one, from the points 1 and 2, making sure that we cross clearly the line AB. This way, we have divided this segment into three equal parts.

DO NOT PRINT THIS PAGE

DO NOT PRINT THIS PAGE

DO NOT PRINT THIS PAGE

DO NOT PRINT THIS PAGE

DO NOT PRINT THIS PAGE

Once the auxiliar lines erased, we draw horizontal lines from every divisory mark. Remember to use your set squares to make sure that these lines are parallel to the horizontal lines of the margin.

DO NOT PRINT THIS PAGE

DO NOT PRINT THIS PAGE

DO NOT PRINT THIS PAGE

DO NOT PRINT THIS PAGE

DO NOT PRINT THIS PAGE

Now, you have divided the available drawing space into three equal parts.

DO NOT PRINT THIS PAGE
DO NOT PRINT THIS PAGE

DO NOT PRINT THIS PAGE
DO NOT PRINT THIS PAGE

We find the centre of each
rectangle by drawing their
diagonals.

DO NOT PRINT THIS PAGE
DO NOT PRINT THIS PAGE

DO NOT PRINT THIS PAGE
DO NOT PRINT THIS PAGE

DO NOT PRINT THIS PAGE
DO NOT PRINT THIS PAGE

DO NOT PRINT THIS PAGE
DO NOT PRINT THIS PAGE

DO NOT PRINT THIS PAGE
DO NOT PRINT THIS PAGE

DO NOT PRINT THIS PAGE
DO NOT PRINT THIS PAGE

After erasing most of the diagonals and leaving only a small x,

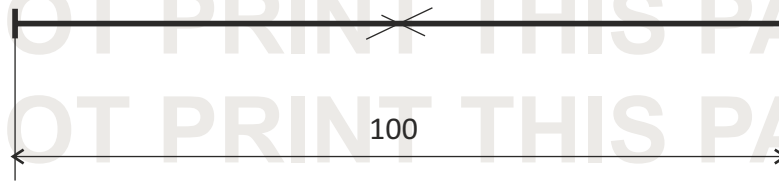

we draw horizontal segments to use as axis of the ovals or part of it on the ovoid.

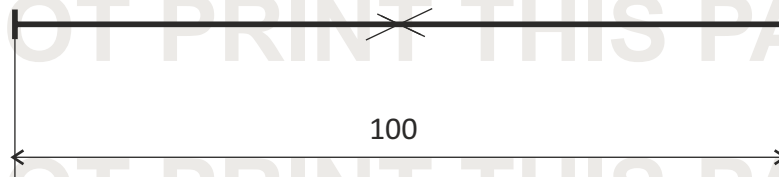

The first two segments must be centered on the rectangle.

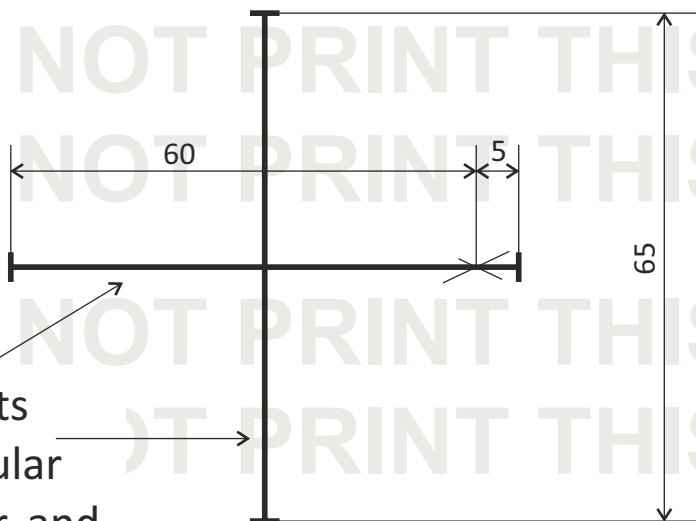

Here you have the lengths to use.

These segments are perpendicular to one another, and cross at their centre.

DO NOT PRINT THIS PAGE
DO NOT PRINT THIS PAGE

DO NOT PRINT THIS PAGE
DO NOT PRINT THIS PAGE

DO NOT PRINT THIS PAGE

DO NOT PRINT THIS PAGE

DO NOT PRINT THIS PAGE
DO NOT PRINT THIS PAGE

DO NOT PRINT THIS PAGE
DO NOT PRINT THIS PAGE

DO NOT PRINT THIS PAGE
DO NOT PRINT THIS PAGE

DO NOT PRINT THIS PAGE
DO NOT PRINT THIS PAGE

DO NOT PRINT THIS PAGE

DO NOT PRINT THIS PAGE

Three parts oval: we start by dividing the long axis into three equal parts.

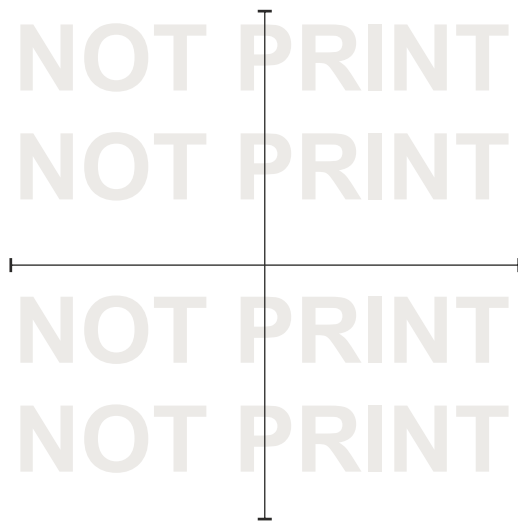
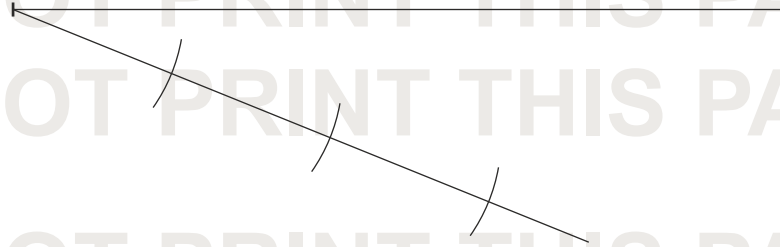

Remember: once the end of the axis (B) and the third mark of the ray (3) connected, we must draw two parallel lines to that one through the marks 1 and 2, using the set squares.

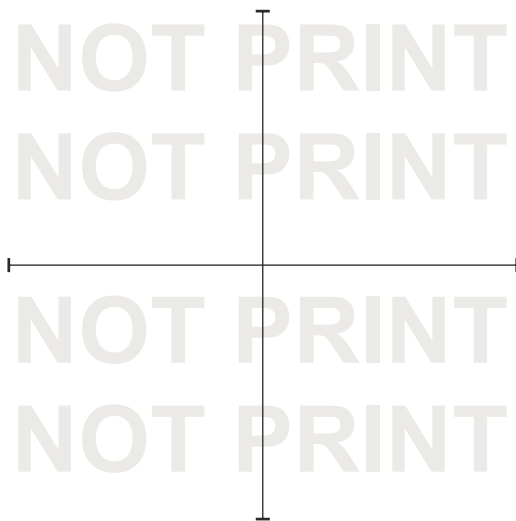
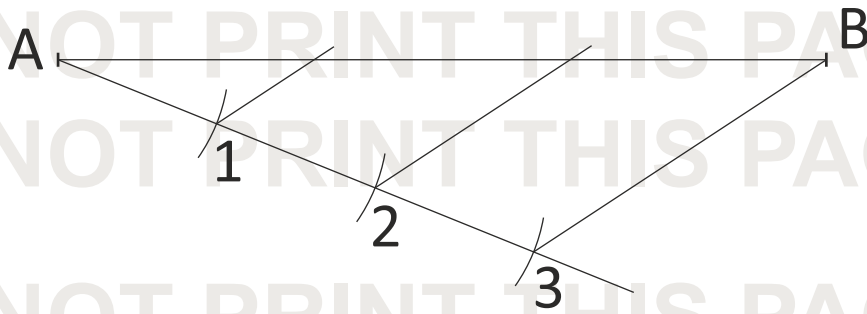

DO NOT PRINT THIS PAGE
DO NOT PRINT THIS PAGE
DO NOT PRINT THIS PAGE
DO NOT PRINT THIS PAGE
DO NOT PRINT THIS PAGE

DO NOT PRINT THIS PAGE
DO NOT PRINT THIS PAGE
DO NOT PRINT THIS PAGE
DO NOT PRINT THIS PAGE
DO NOT PRINT THIS PAGE

DO NOT PRINT THIS PAGE
DO NOT PRINT THIS PAGE
DO NOT PRINT THIS PAGE
DO NOT PRINT THIS PAGE

DO NOT PRINT THIS PAGE

DO NOT PRINT THIS PAGE

DO NOT PRINT THIS PAGE
DO NOT PRINT THIS PAGE
DO NOT PRINT THIS PAGE
DO NOT PRINT THIS PAGE
DO NOT PRINT THIS PAGE

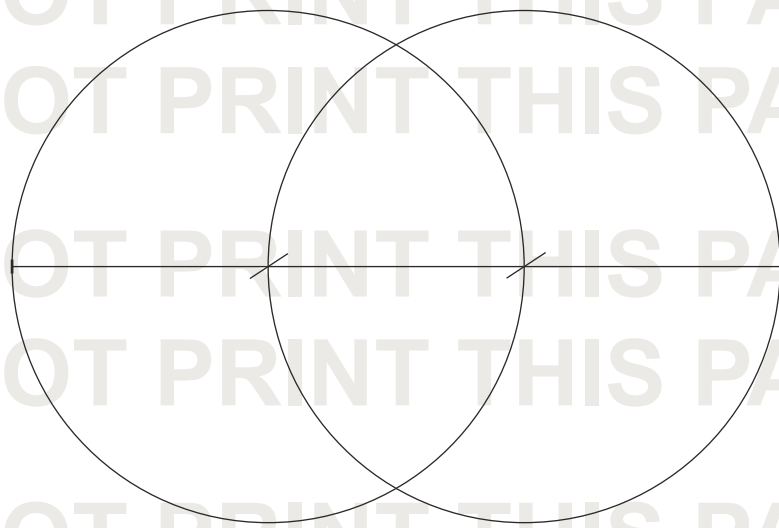

DO NOT PRINT THIS PAGE
DO NOT PRINT THIS PAGE
DO NOT PRINT THIS PAGE
DO NOT PRINT THIS PAGE
DO NOT PRINT THIS PAGE



DO NOT PRINT THIS PAGE
DO NOT PRINT THIS PAGE
DO NOT PRINT THIS PAGE
DO NOT PRINT THIS PAGE

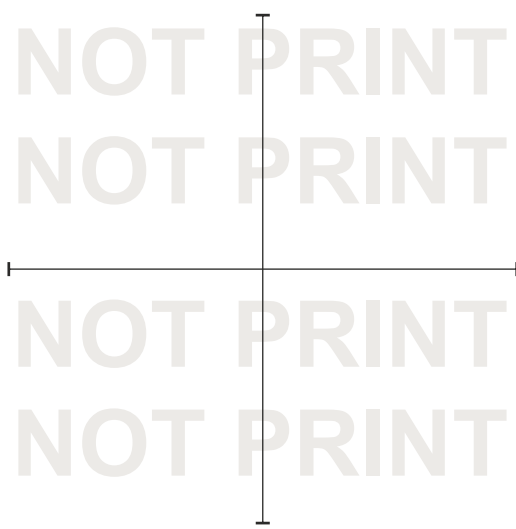

DO NOT PRINT THIS PAGE
DO NOT PRINT THIS PAGE

DO NOT PRINT THIS PAGE
DO NOT PRINT THIS PAGE
DO NOT PRINT THIS PAGE
DO NOT PRINT THIS PAGE
DO NOT PRINT THIS PAGE

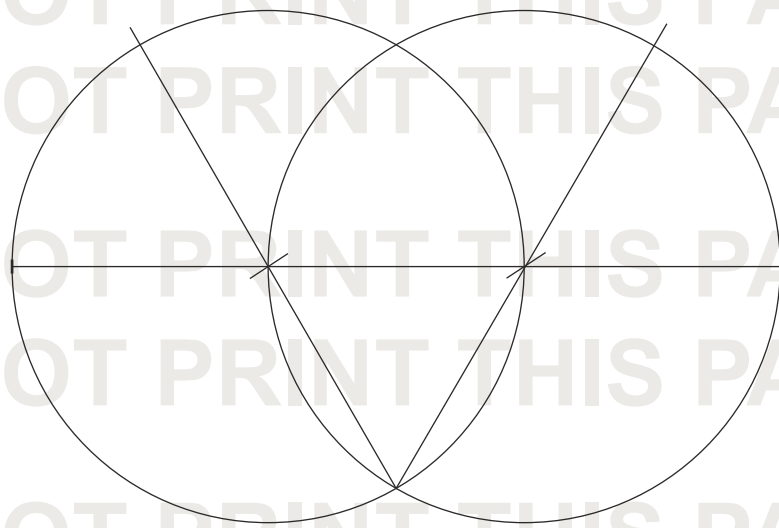

DO NOT PRINT THIS PAGE
DO NOT PRINT THIS PAGE
DO NOT PRINT THIS PAGE
DO NOT PRINT THIS PAGE



DO NOT PRINT THIS PAGE
DO NOT PRINT THIS PAGE
DO NOT PRINT THIS PAGE
DO NOT PRINT THIS PAGE

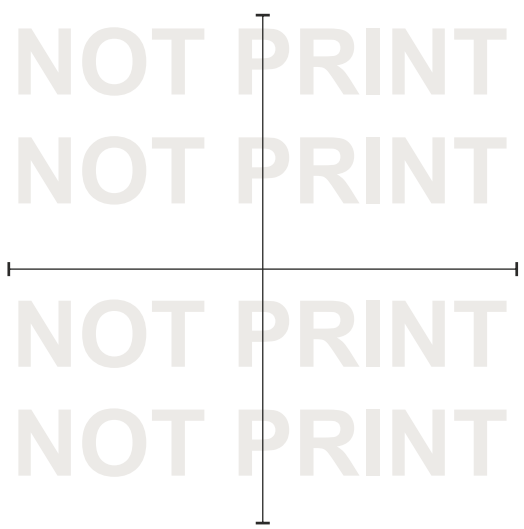

DO NOT PRINT THIS PAGE
DO NOT PRINT THIS PAGE

DO NOT PRINT THIS PAGE

DO NOT PRINT THIS PAGE

DO NOT PRINT THIS PAGE

DO NOT PRINT THIS PAGE

DO NOT PRINT THIS PAGE

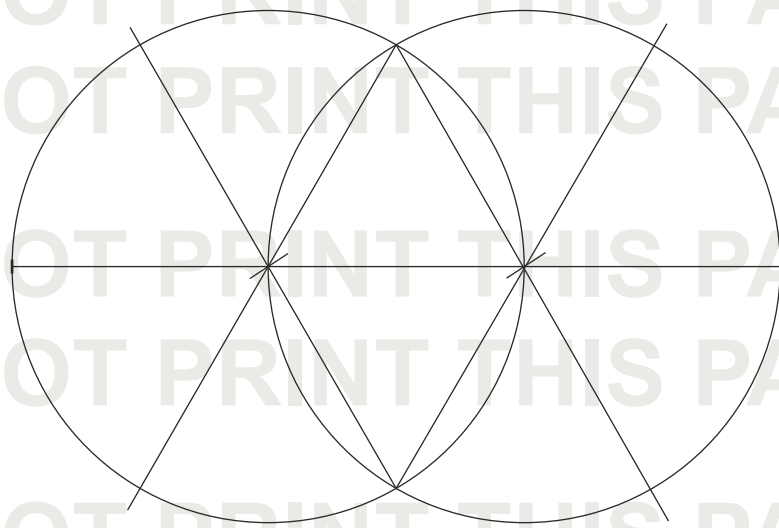

DO NOT PRINT THIS PAGE

DO NOT PRINT THIS PAGE

DO NOT PRINT THIS PAGE



DO NOT PRINT THIS PAGE

DO NOT PRINT THIS PAGE

DO NOT PRINT THIS PAGE

DO NOT PRINT THIS PAGE

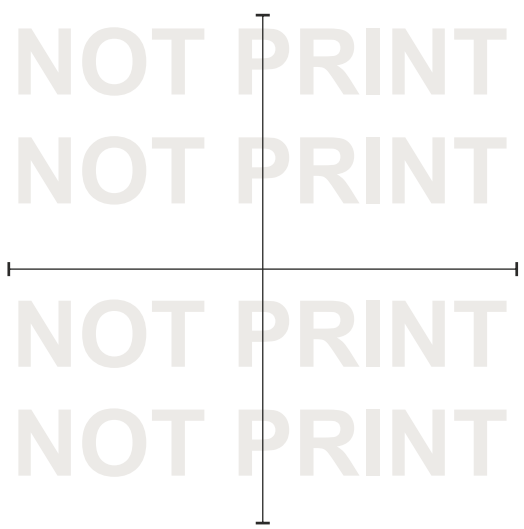

DO NOT PRINT THIS PAGE

DO NOT PRINT THIS PAGE

DO NOT PRINT THIS PAGE

DO NOT PRINT THIS PAGE

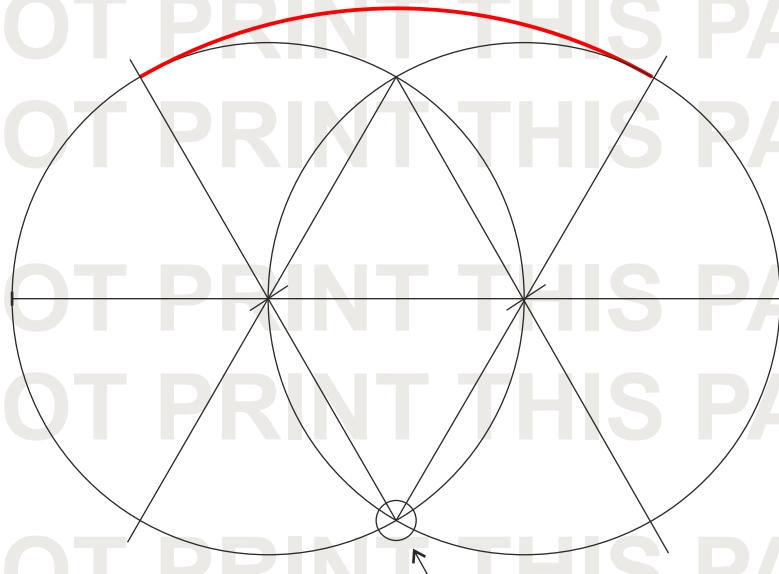

Centre of the arc

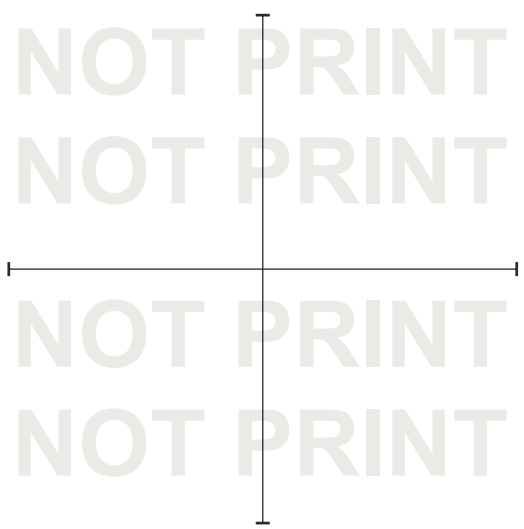

Centre of the arc

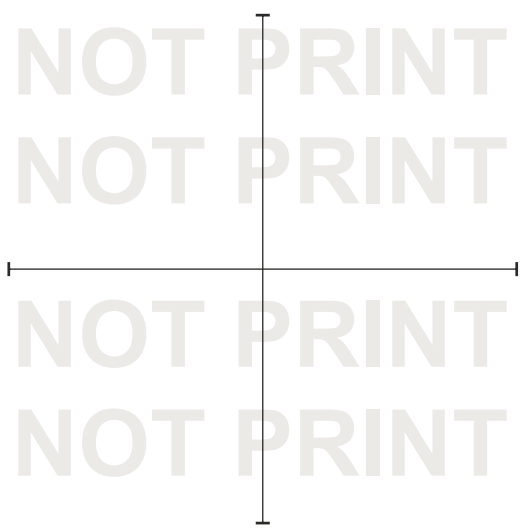
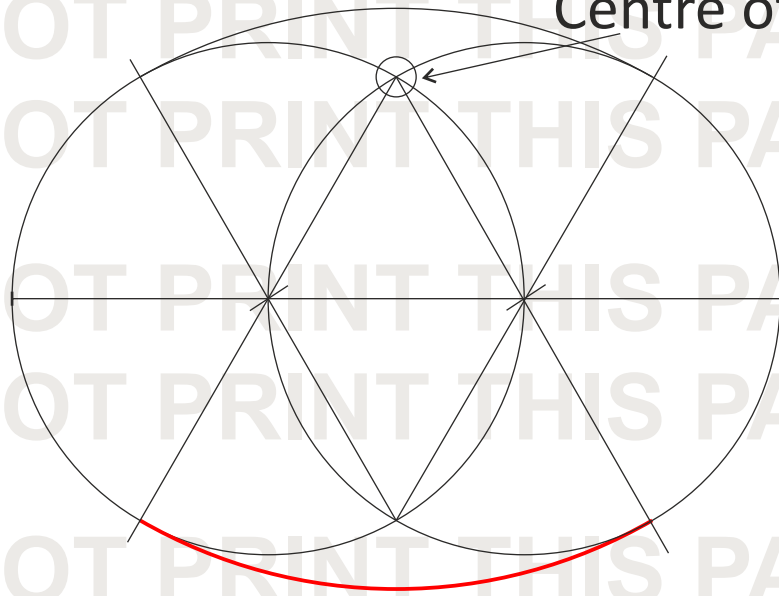

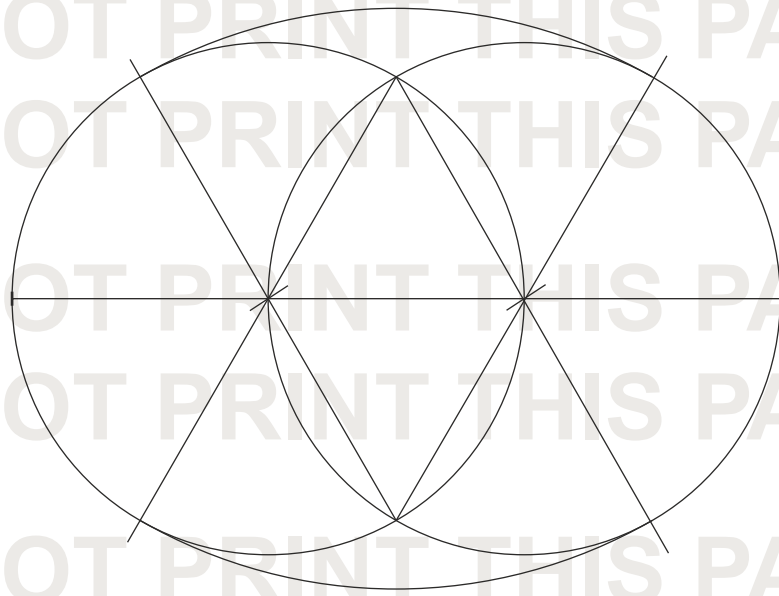

The second segment must be divided into four equal parts.

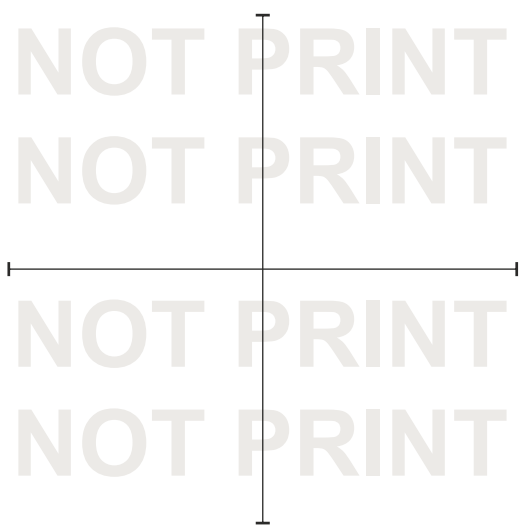
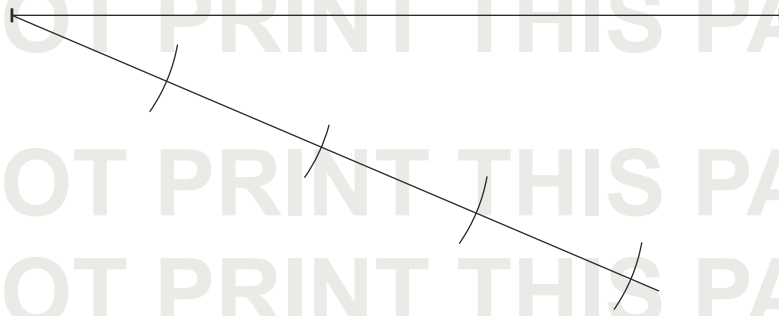

DO NOT PRINT THIS PAGE
DO NOT PRINT THIS PAGE
DO NOT PRINT THIS PAGE
DO NOT PRINT THIS PAGE
DO NOT PRINT THIS PAGE

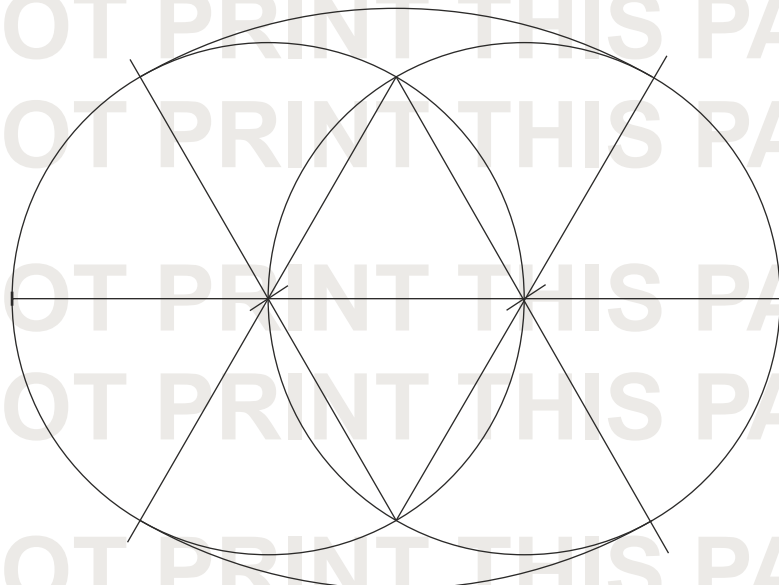

DO NOT PRINT THIS PAGE
DO NOT PRINT THIS PAGE
DO NOT PRINT THIS PAGE
DO NOT PRINT THIS PAGE

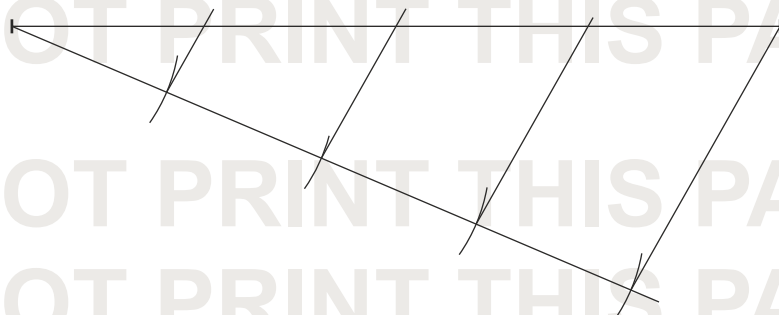

DO NOT PRINT THIS PAGE
DO NOT PRINT THIS PAGE
DO NOT PRINT THIS PAGE
DO NOT PRINT THIS PAGE

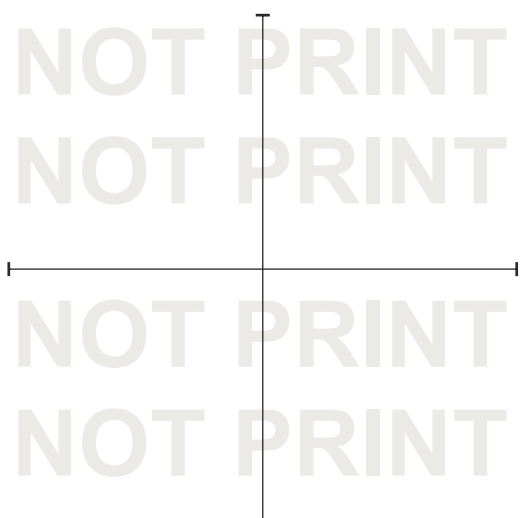

DO NOT PRINT THIS PAGE
DO NOT PRINT THIS PAGE

DO NOT PRINT THIS PAGE
DO NOT PRINT THIS PAGE
DO NOT PRINT THIS PAGE
DO NOT PRINT THIS PAGE
DO NOT PRINT THIS PAGE

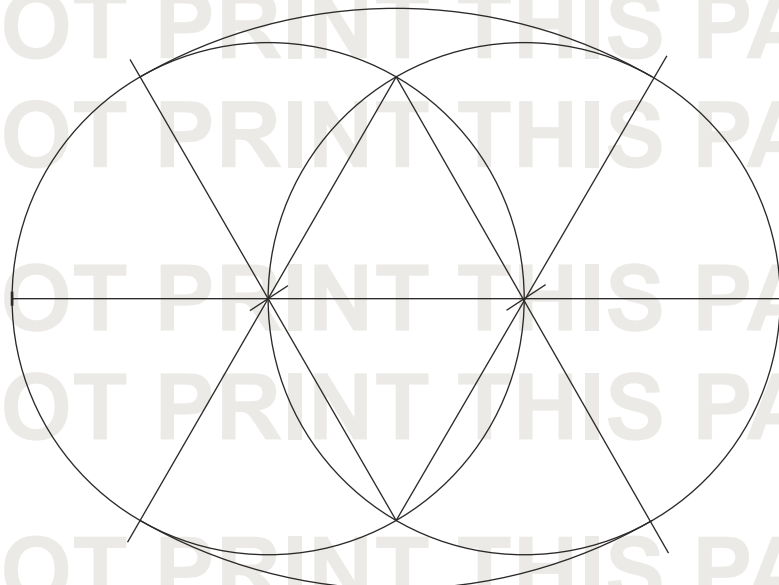

DO NOT PRINT THIS PAGE
DO NOT PRINT THIS PAGE
DO NOT PRINT THIS PAGE
DO NOT PRINT THIS PAGE



DO NOT PRINT THIS PAGE
DO NOT PRINT THIS PAGE
DO NOT PRINT THIS PAGE
DO NOT PRINT THIS PAGE

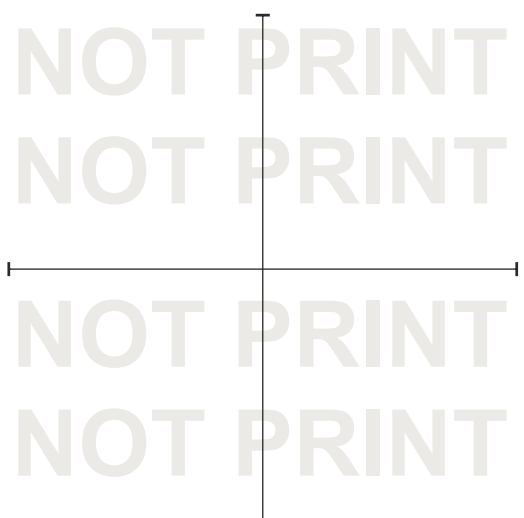

DO NOT PRINT THIS PAGE
DO NOT PRINT THIS PAGE

DO NOT PRINT THIS PAGE
DO NOT PRINT THIS PAGE
DO NOT PRINT THIS PAGE
DO NOT PRINT THIS PAGE
DO NOT PRINT THIS PAGE

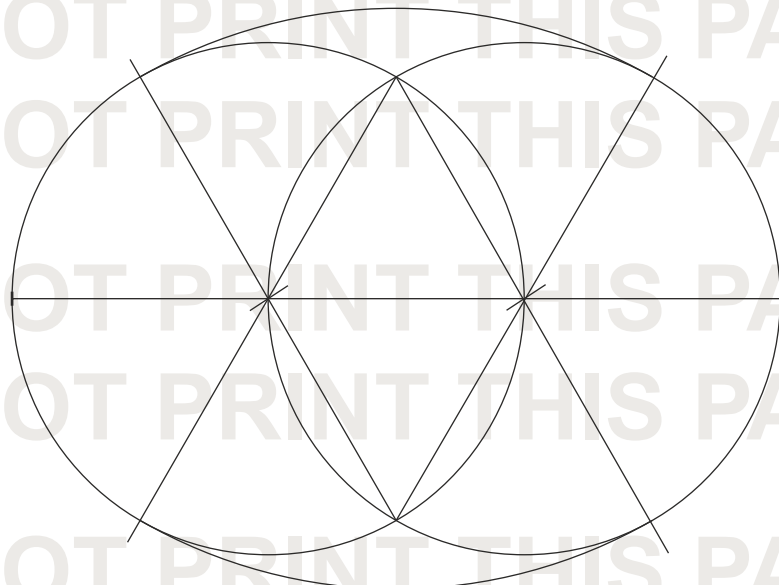

DO NOT PRINT THIS PAGE
DO NOT PRINT THIS PAGE
DO NOT PRINT THIS PAGE
DO NOT PRINT THIS PAGE

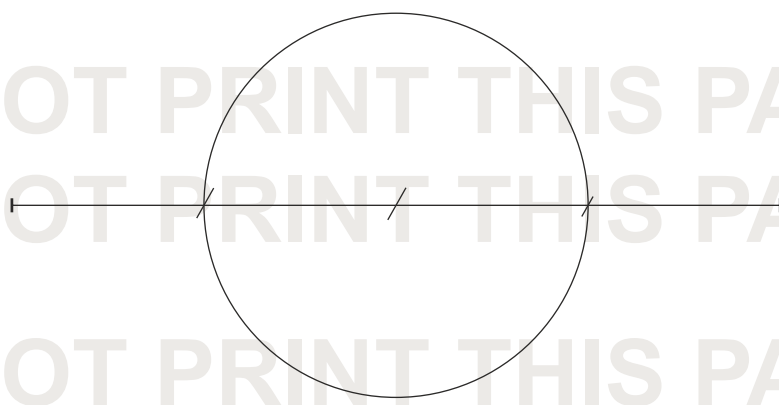

DO NOT PRINT THIS PAGE
DO NOT PRINT THIS PAGE
DO NOT PRINT THIS PAGE
DO NOT PRINT THIS PAGE

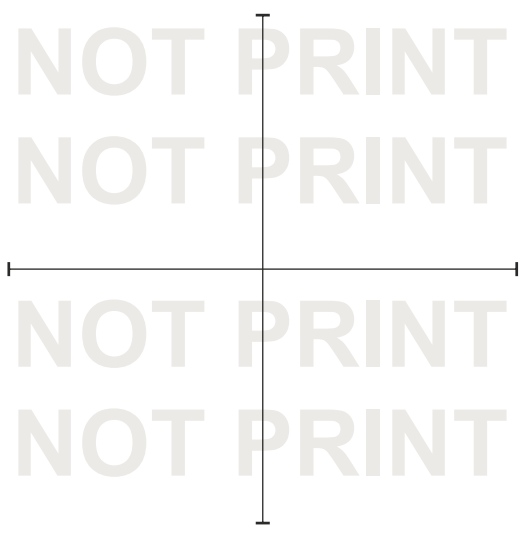

DO NOT PRINT THIS PAGE
DO NOT PRINT THIS PAGE

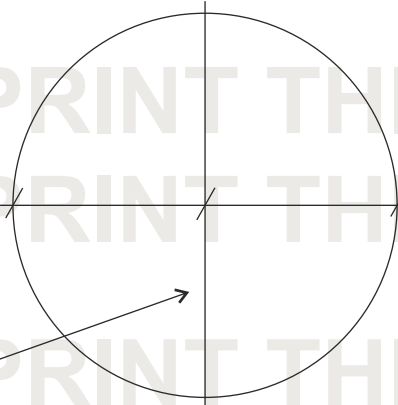
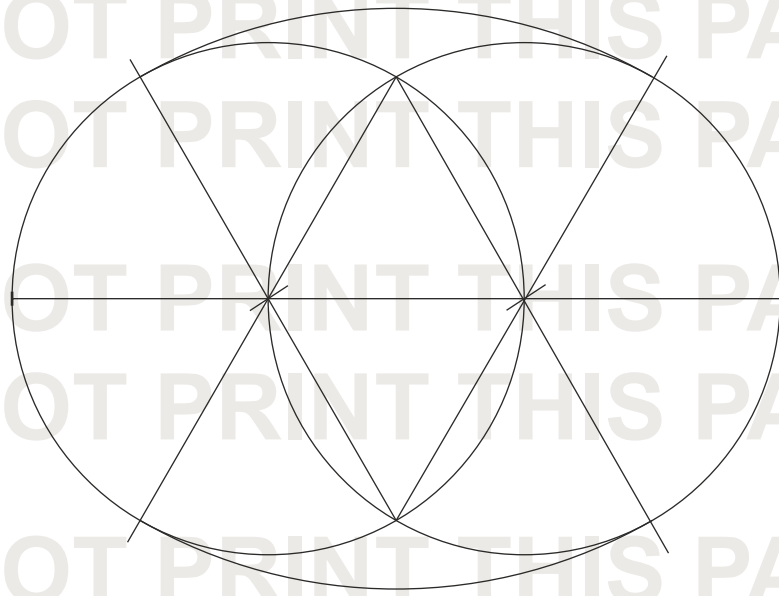

This diameter must be perpendicular to the long axis (please use the set squares).

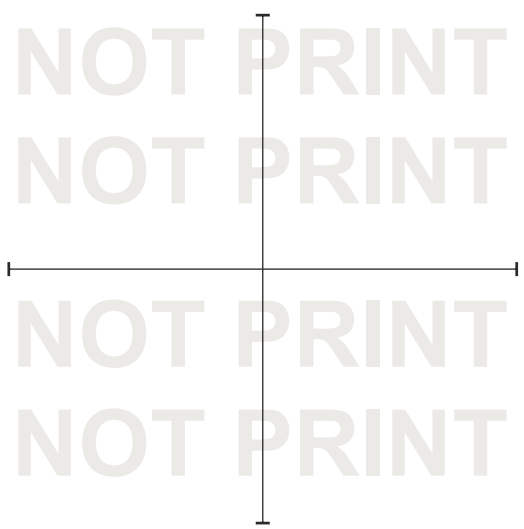

DO NOT PRINT THIS PAGE
DO NOT PRINT THIS PAGE
DO NOT PRINT THIS PAGE
DO NOT PRINT THIS PAGE
DO NOT PRINT THIS PAGE

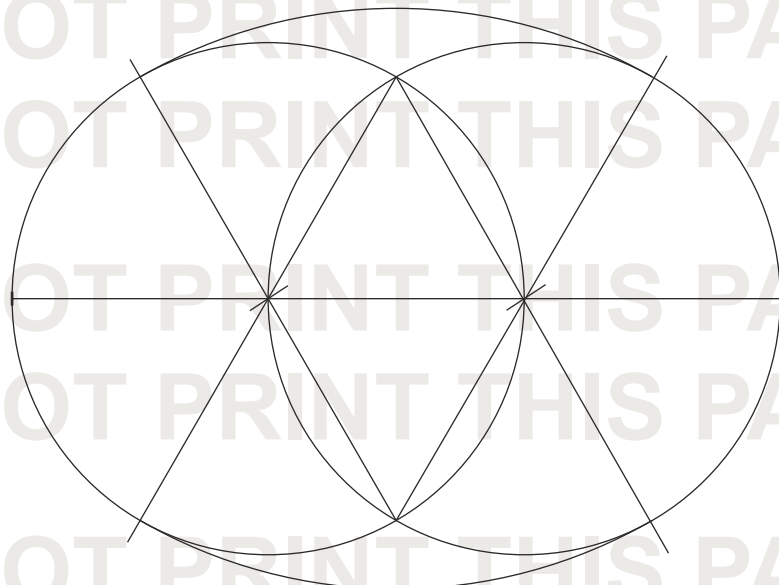

DO NOT PRINT THIS PAGE
DO NOT PRINT THIS PAGE
DO NOT PRINT THIS PAGE
DO NOT PRINT THIS PAGE

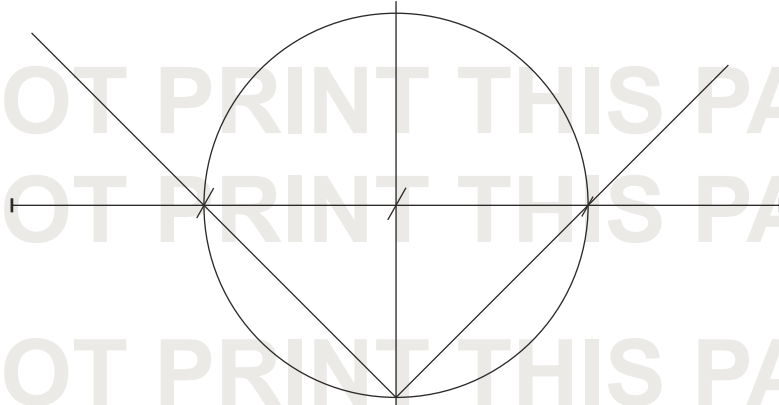

DO NOT PRINT THIS PAGE
DO NOT PRINT THIS PAGE
DO NOT PRINT THIS PAGE
DO NOT PRINT THIS PAGE

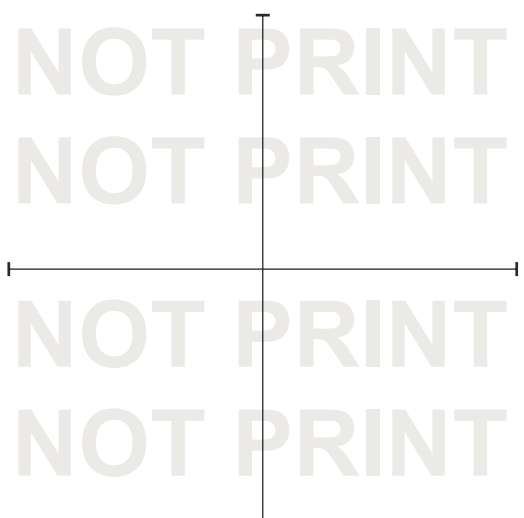

DO NOT PRINT THIS PAGE
DO NOT PRINT THIS PAGE

DO NOT PRINT THIS PAGE
DO NOT PRINT THIS PAGE
DO NOT PRINT THIS PAGE
DO NOT PRINT THIS PAGE
DO NOT PRINT THIS PAGE

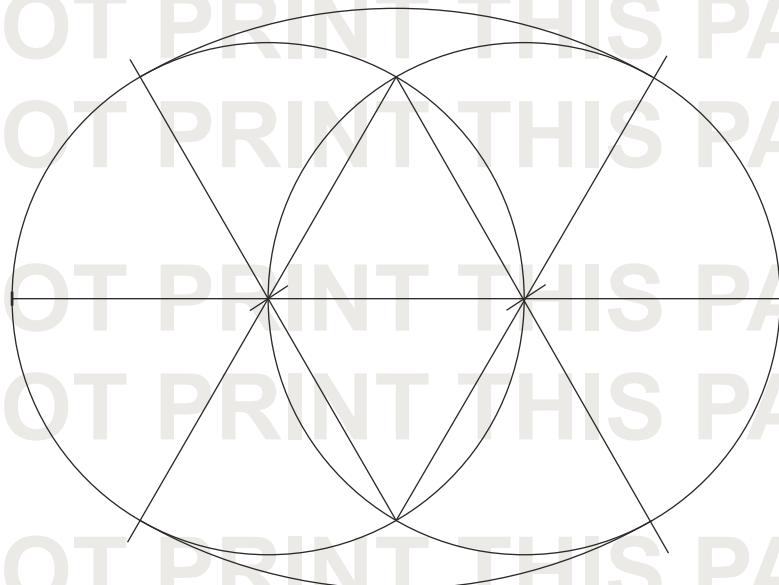

DO NOT PRINT THIS PAGE
DO NOT PRINT THIS PAGE
DO NOT PRINT THIS PAGE
DO NOT PRINT THIS PAGE

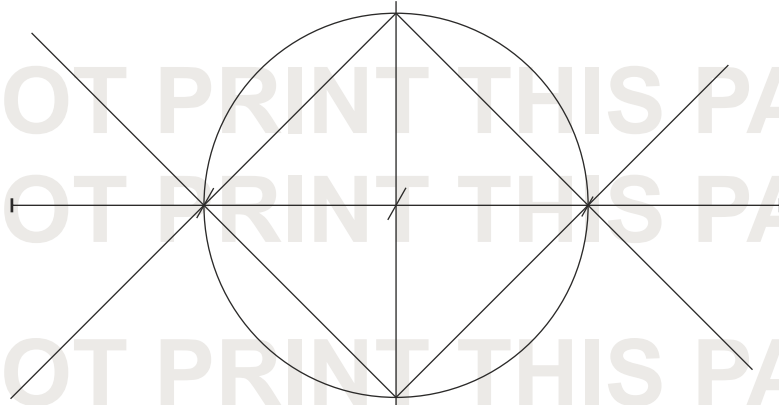

DO NOT PRINT THIS PAGE
DO NOT PRINT THIS PAGE
DO NOT PRINT THIS PAGE
DO NOT PRINT THIS PAGE

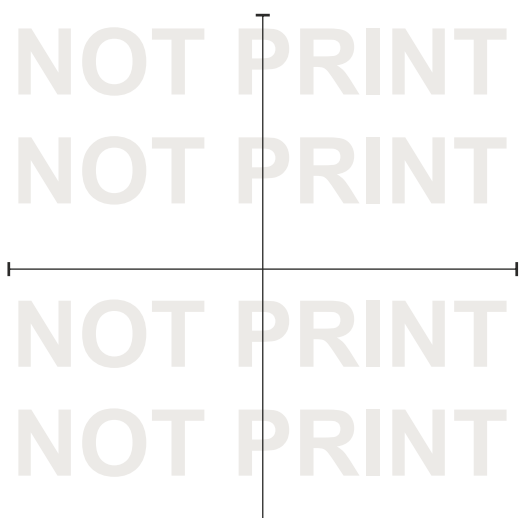

DO NOT PRINT THIS PAGE
DO NOT PRINT THIS PAGE

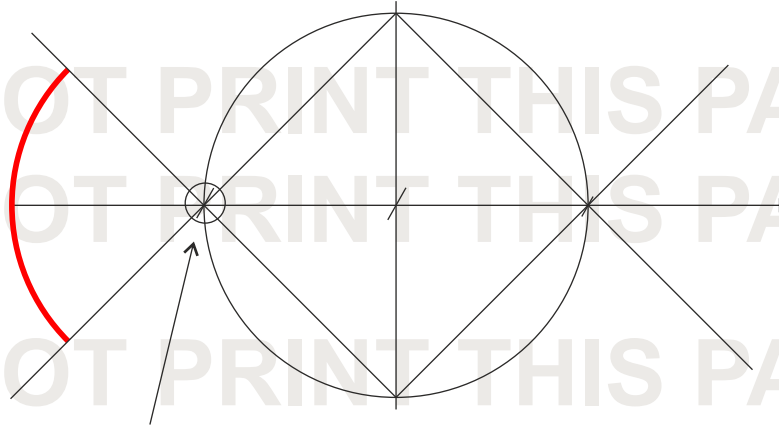
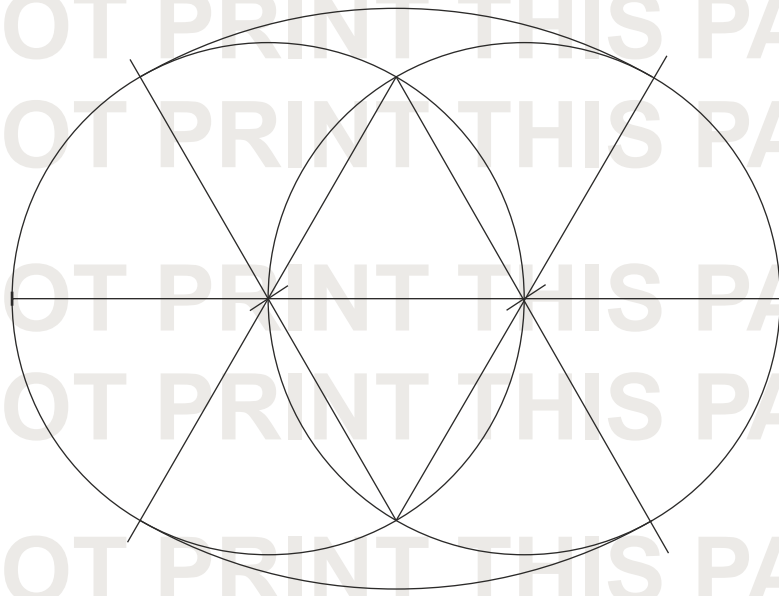

Centre of the arc

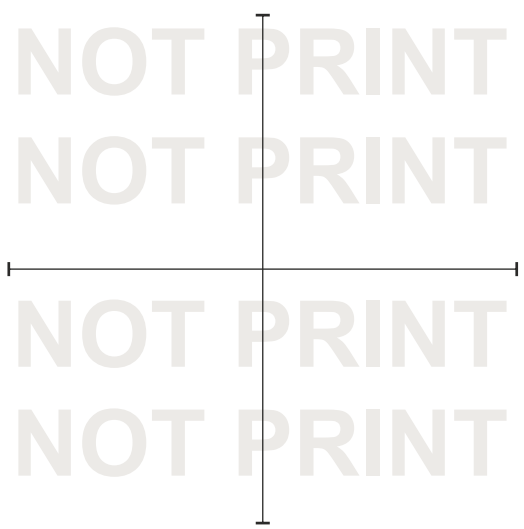

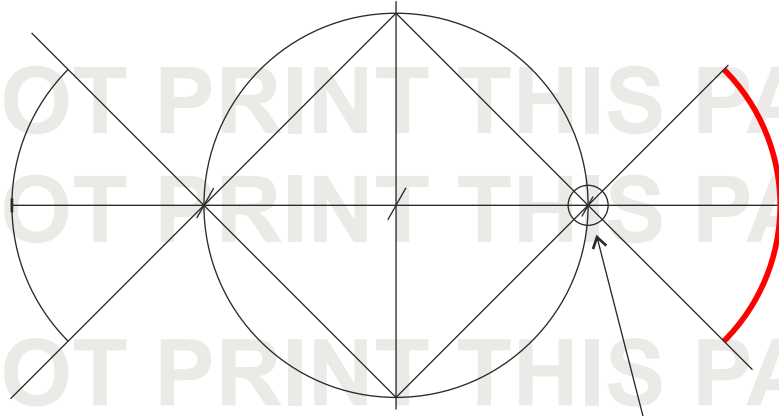
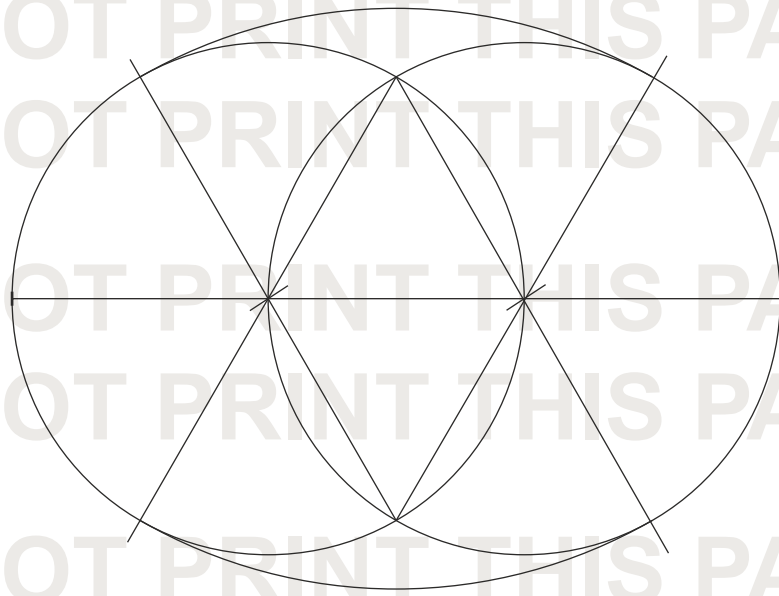

Centre of the arc

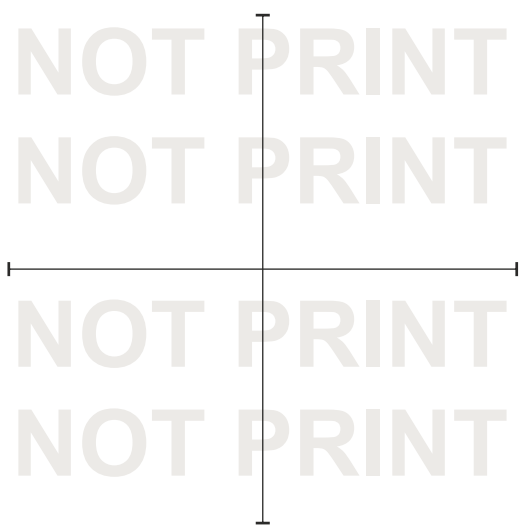

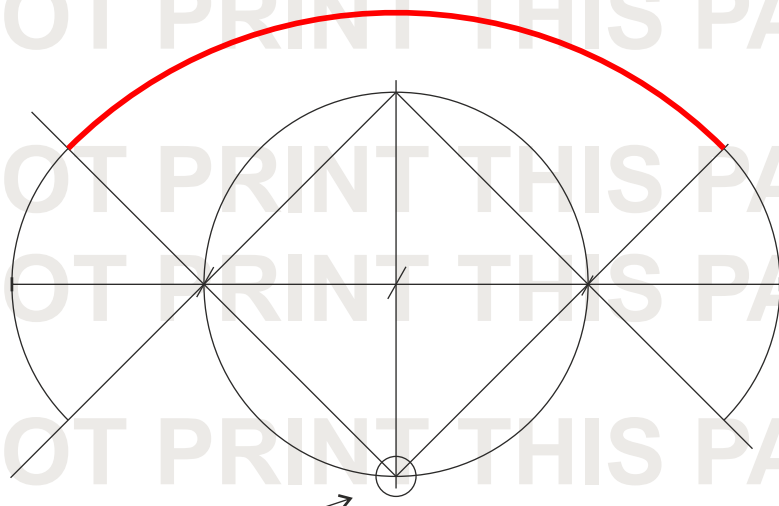
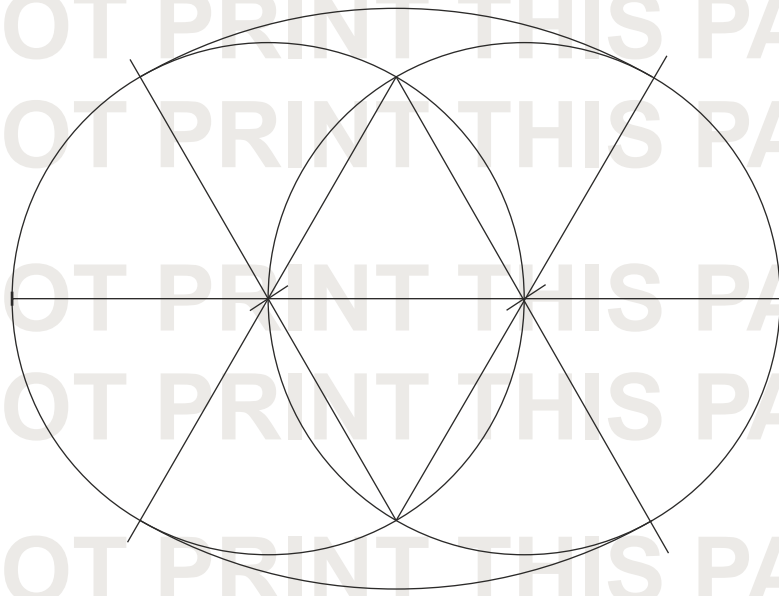

Centre of the arc

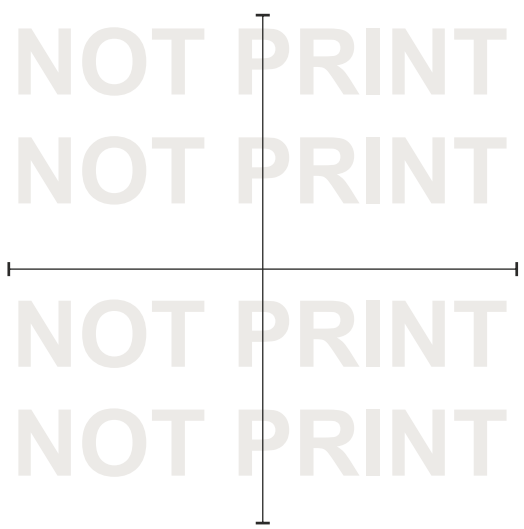

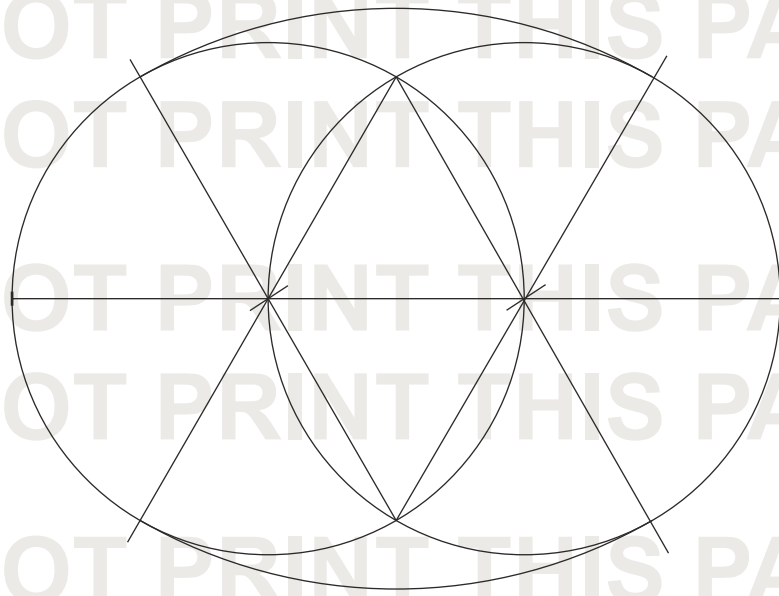

Centre of the arc

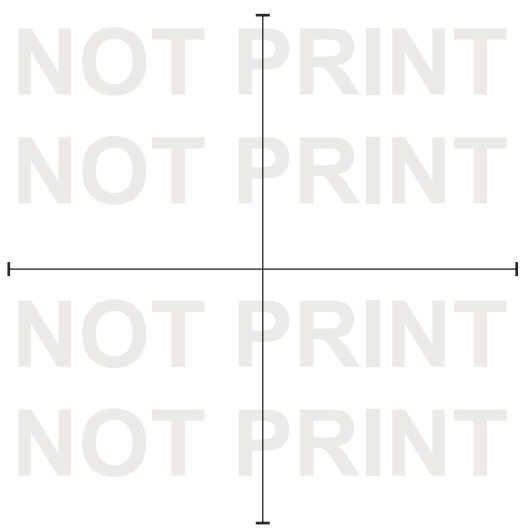
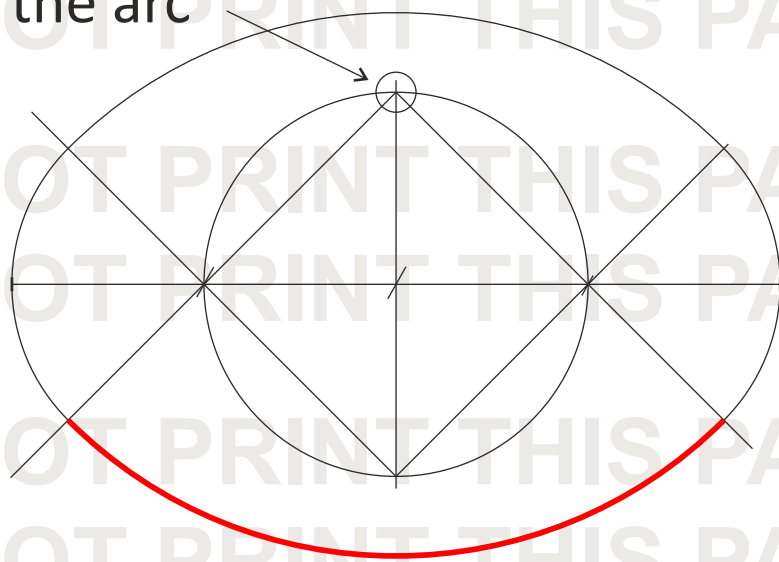

DO NOT PRINT THIS PAGE
DO NOT PRINT THIS PAGE
DO NOT PRINT THIS PAGE
DO NOT PRINT THIS PAGE
DO NOT PRINT THIS PAGE

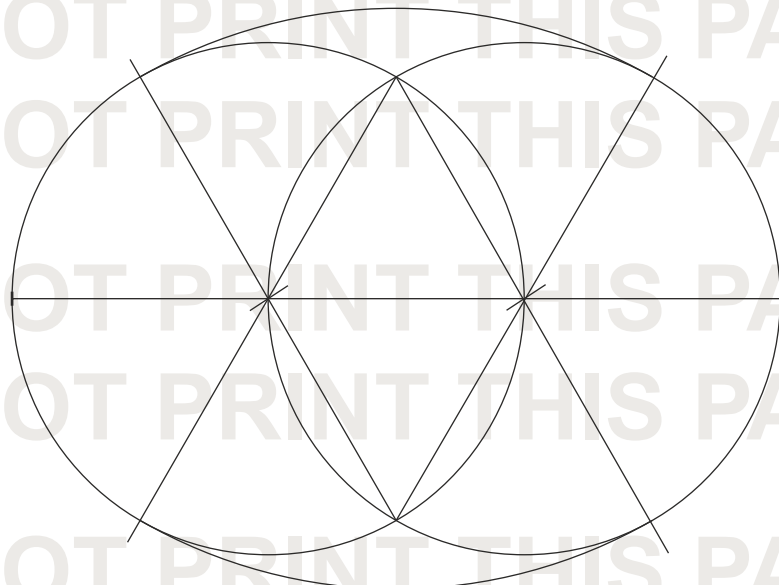

DO NOT PRINT THIS PAGE
DO NOT PRINT THIS PAGE
DO NOT PRINT THIS PAGE
DO NOT PRINT THIS PAGE

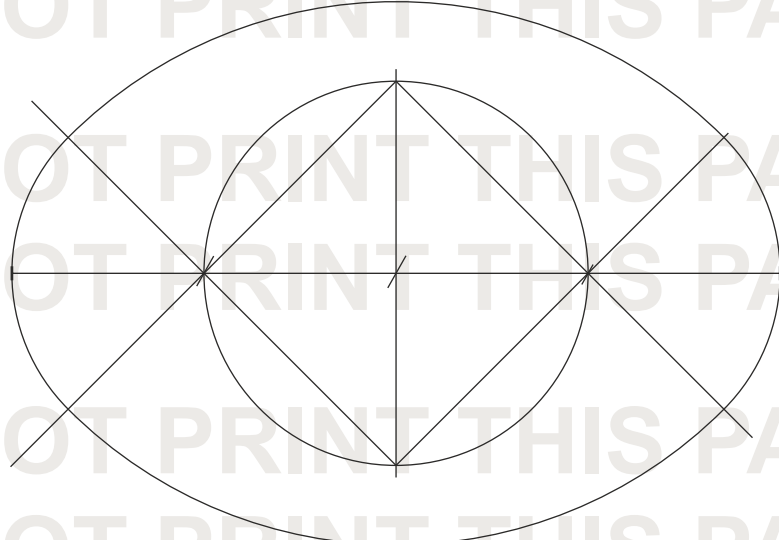

DO NOT PRINT THIS PAGE
DO NOT PRINT THIS PAGE
DO NOT PRINT THIS PAGE
DO NOT PRINT THIS PAGE

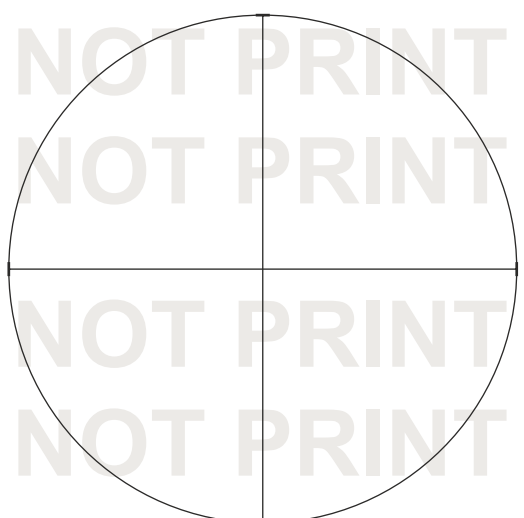

DO NOT PRINT THIS PAGE
DO NOT PRINT THIS PAGE

DO NOT PRINT THIS PAGE
DO NOT PRINT THIS PAGE
DO NOT PRINT THIS PAGE
DO NOT PRINT THIS PAGE
DO NOT PRINT THIS PAGE

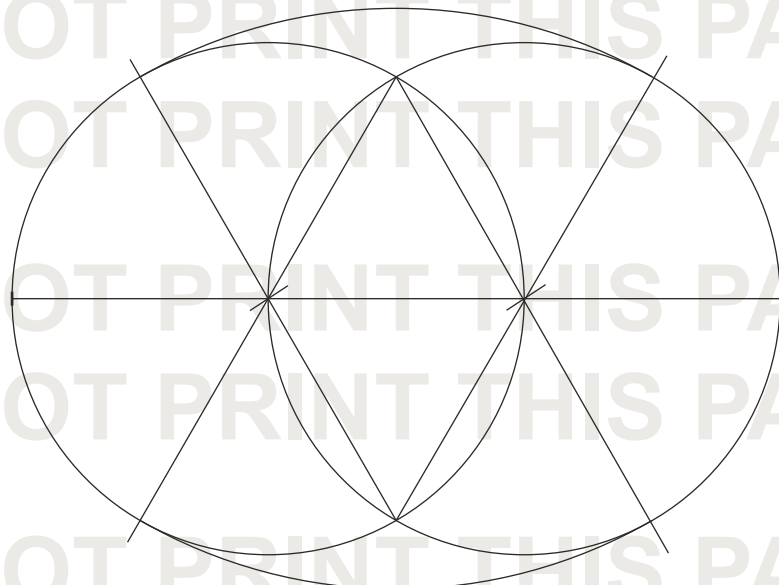

DO NOT PRINT THIS PAGE
DO NOT PRINT THIS PAGE
DO NOT PRINT THIS PAGE
DO NOT PRINT THIS PAGE

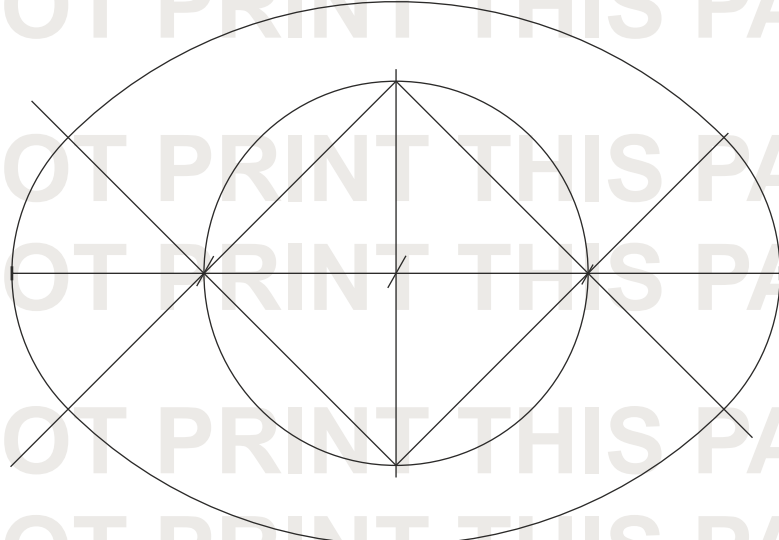

DO NOT PRINT THIS PAGE
DO NOT PRINT THIS PAGE
DO NOT PRINT THIS PAGE
DO NOT PRINT THIS PAGE

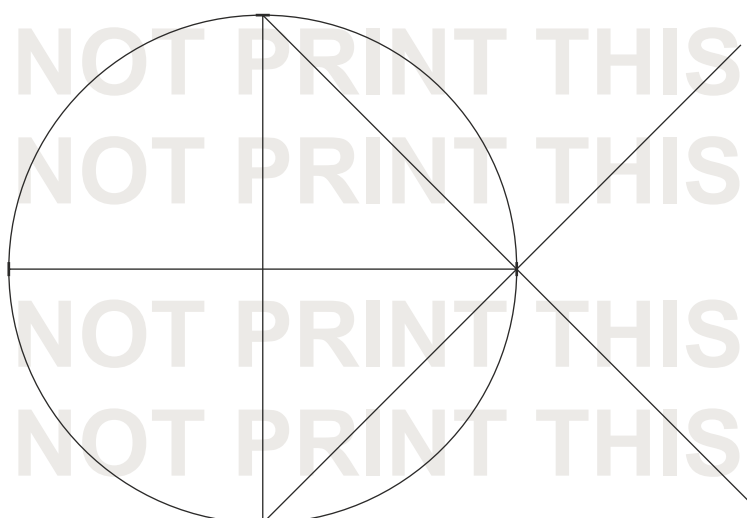

DO NOT PRINT THIS PAGE
DO NOT PRINT THIS PAGE

DO NOT PRINT THIS PAGE
DO NOT PRINT THIS PAGE
DO NOT PRINT THIS PAGE
DO NOT PRINT THIS PAGE
DO NOT PRINT THIS PAGE

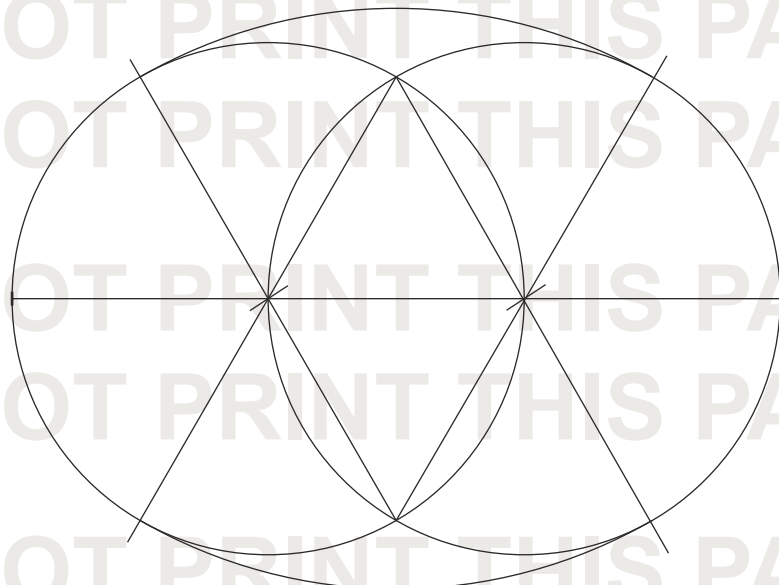

DO NOT PRINT THIS PAGE
DO NOT PRINT THIS PAGE
DO NOT PRINT THIS PAGE
DO NOT PRINT THIS PAGE
DO NOT PRINT THIS PAGE

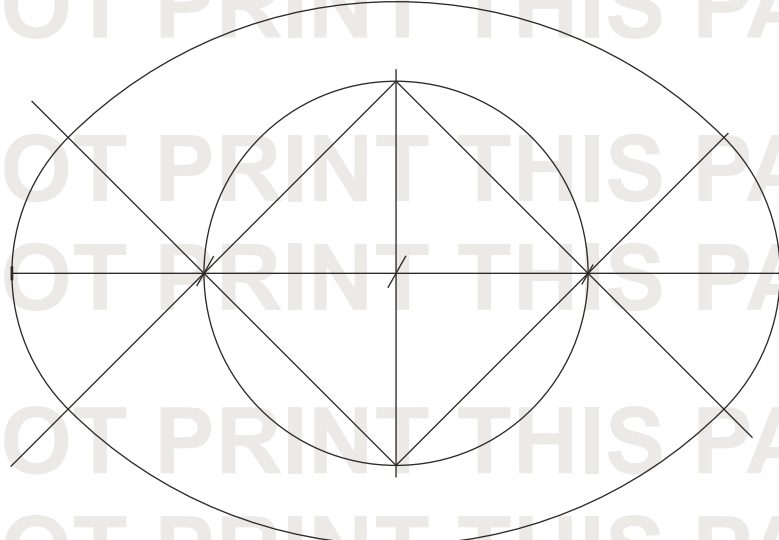

DO NOT PRINT THIS PAGE
DO NOT PRINT THIS PAGE
DO NOT PRINT THIS PAGE
DO NOT PRINT THIS PAGE
DO NOT PRINT THIS PAGE

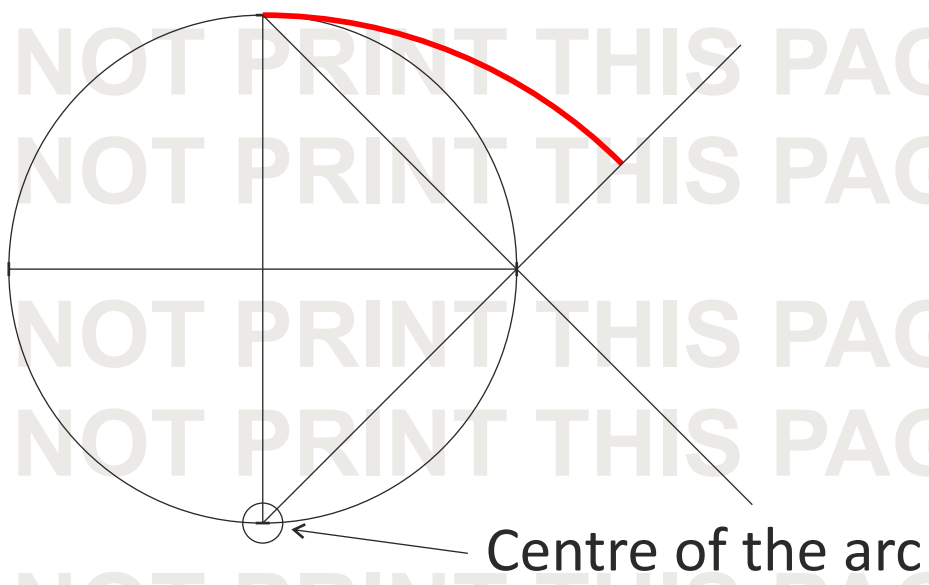

DO NOT PRINT THIS PAGE
DO NOT PRINT THIS PAGE

DO NOT PRINT THIS PAGE
DO NOT PRINT THIS PAGE
DO NOT PRINT THIS PAGE
DO NOT PRINT THIS PAGE
DO NOT PRINT THIS PAGE

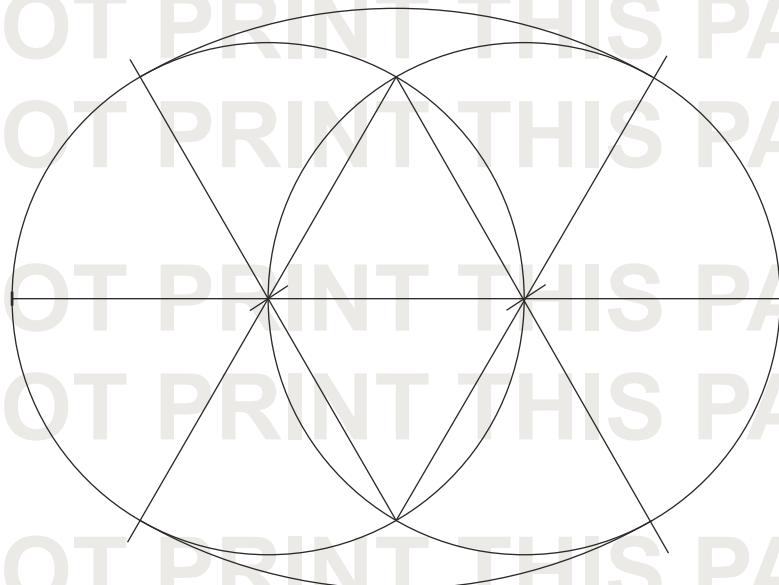

DO NOT PRINT THIS PAGE
DO NOT PRINT THIS PAGE
DO NOT PRINT THIS PAGE
DO NOT PRINT THIS PAGE
DO NOT PRINT THIS PAGE

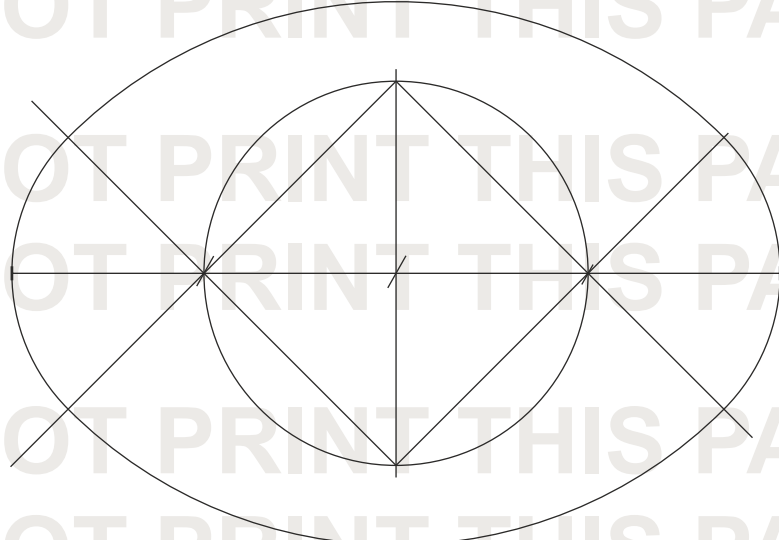

DO NOT PRINT THIS PAGE
DO NOT PRINT THIS PAGE
DO NOT PRINT THIS PAGE
DO NOT PRINT THIS PAGE
DO NOT PRINT THIS PAGE

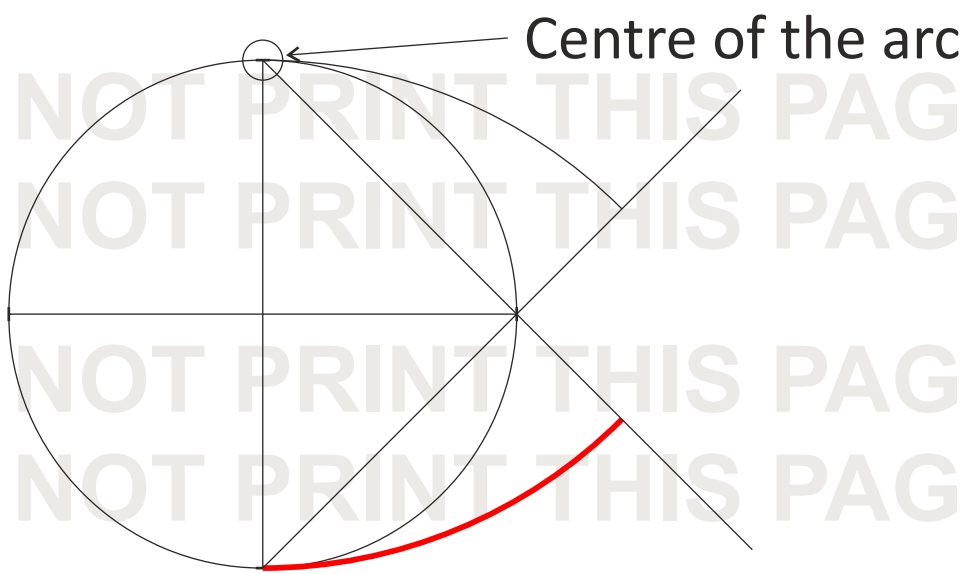

DO NOT PRINT THIS PAGE
DO NOT PRINT THIS PAGE

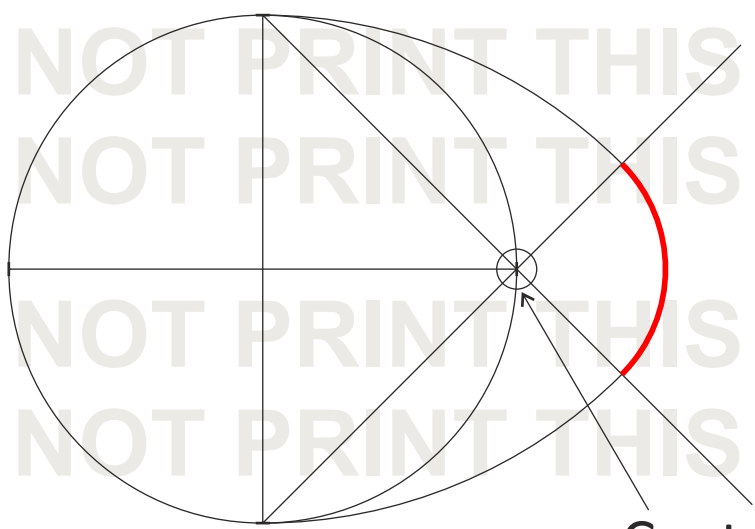
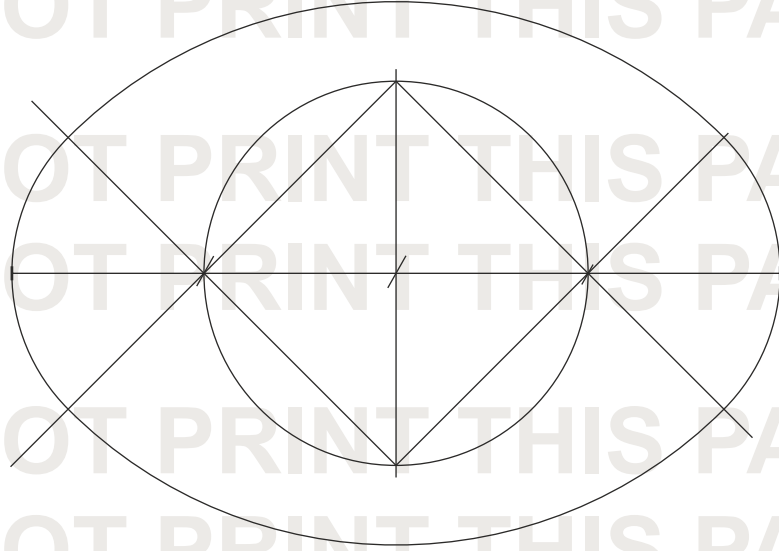
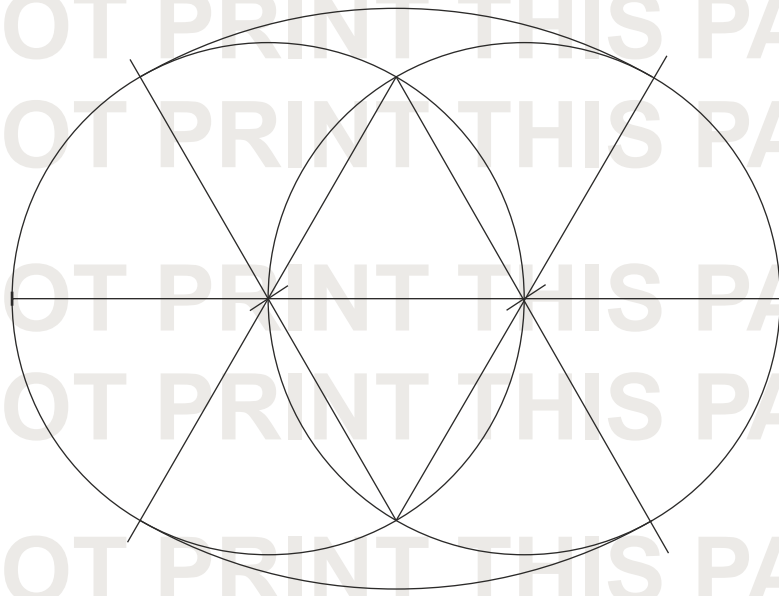

Centre of the arc

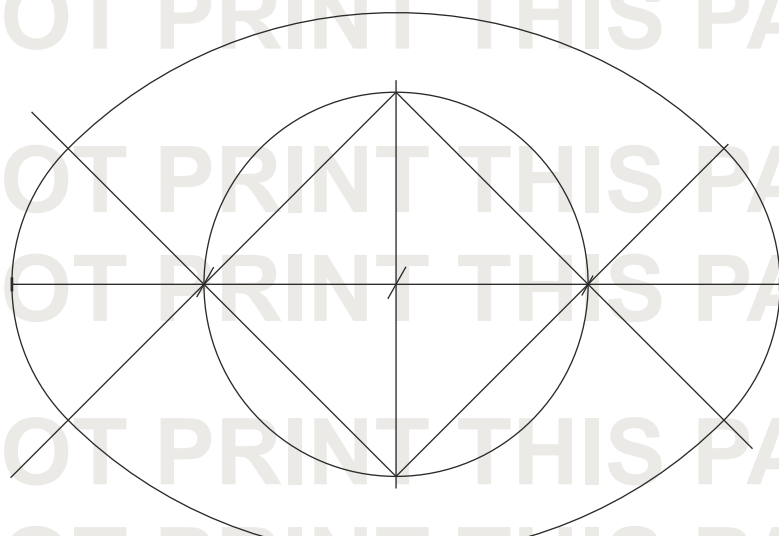
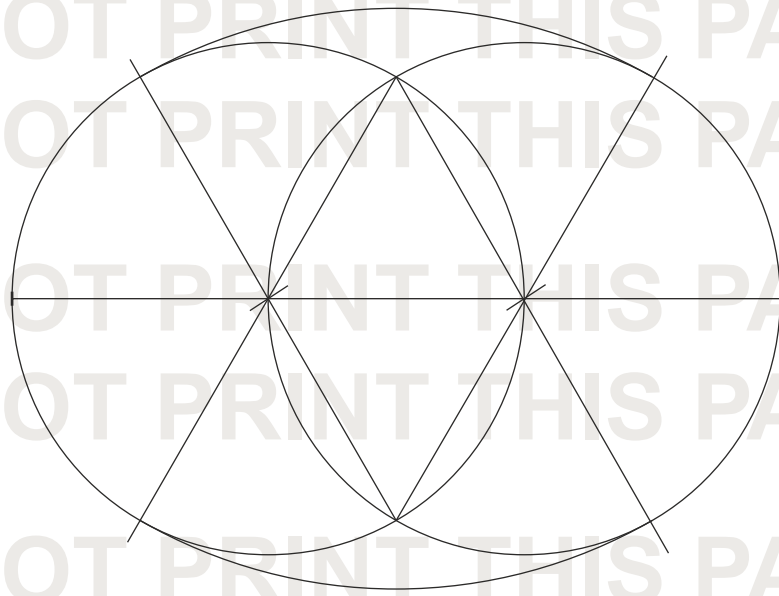

At this stage, please make a photocopy of the drawing and keep it.

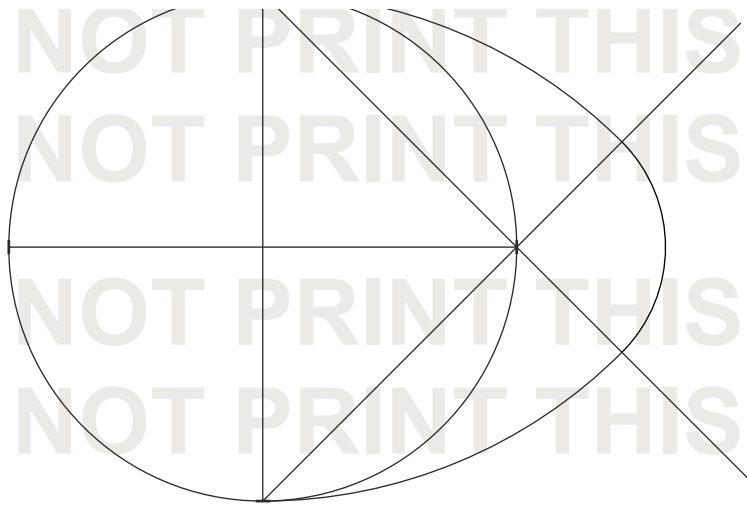

DO NOT PRINT THIS PAGE

DO NOT PRINT THIS PAGE

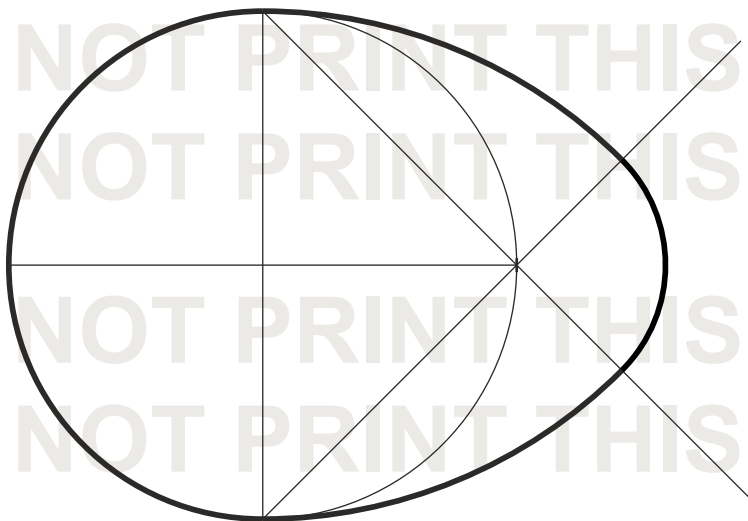
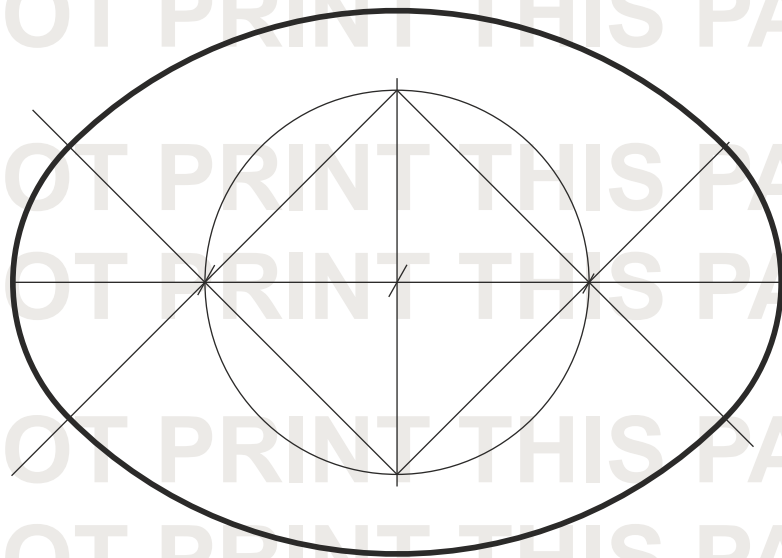
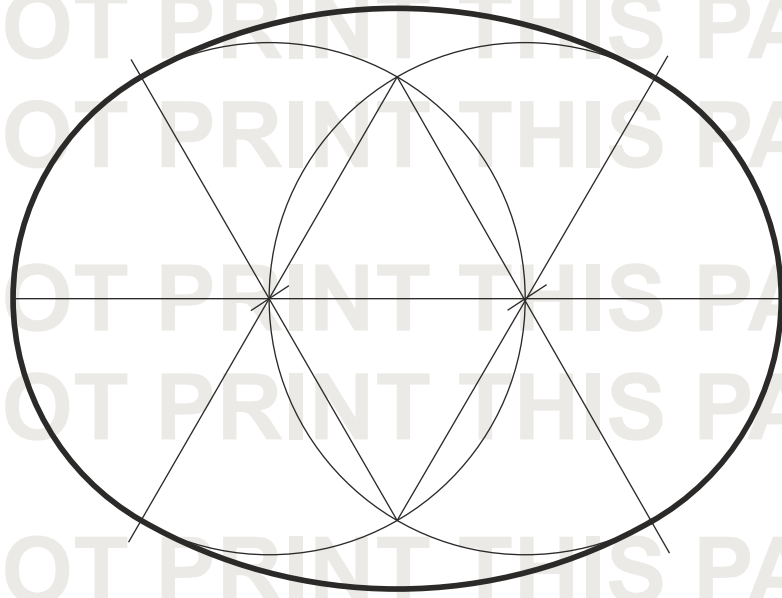

Now, we ink in the lines, using calibrated markers. Use the 0.8 mm for the outline of the figures, the margin and the boxes, and the 0.2 for the rest of the lines

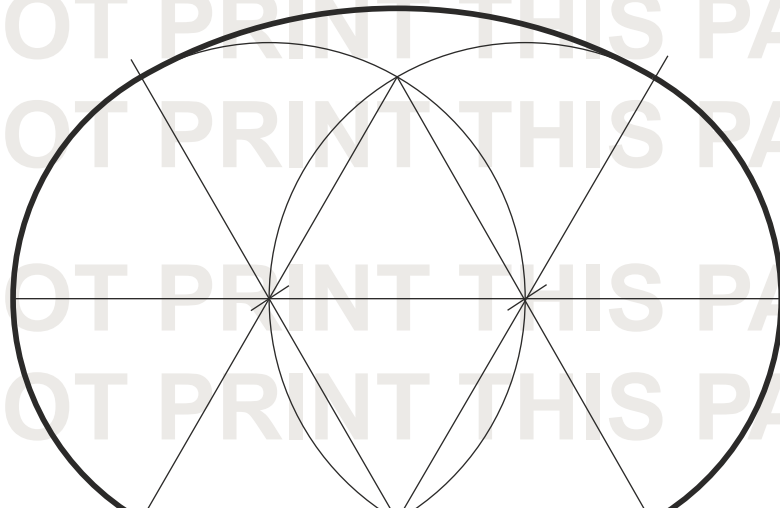

Finally, we identify our work, using the 0.4 calibrated marker and in capital letters, and submit it to the teacher, along with the photocopy we previously made.

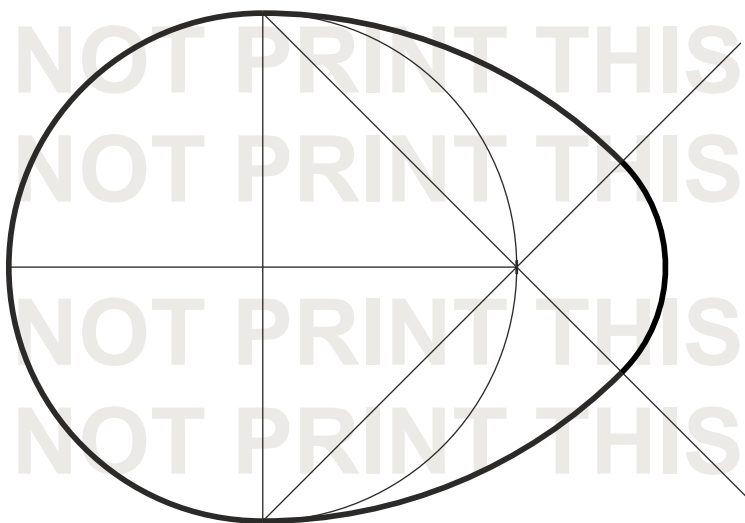
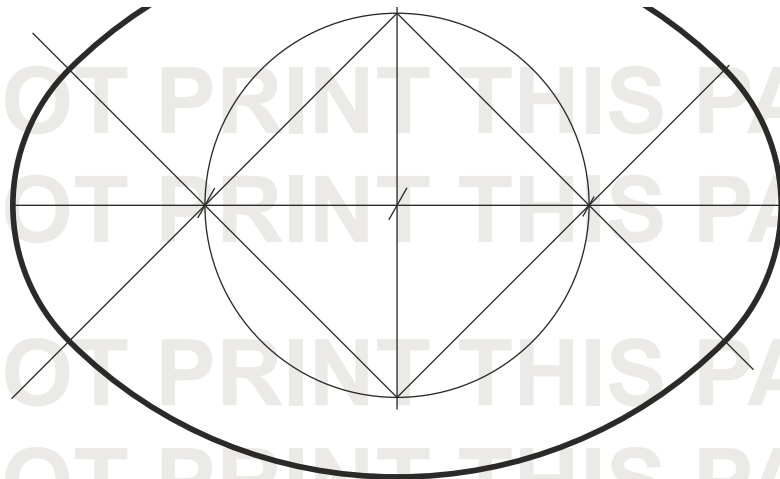

OVALS AND OVOID

DATE

NAME AND SURNAME

GROUP